

REVIEW

Fluid mechanical aspects of suspension feeding

C. Barker Jørgensen

Zoophysiological Laboratory A, August Krogh Institute, Universitetsparken 13, DK-2100 Copenhagen Ø, Denmark

ABSTRACT: Most accounts on suspension feeding assume that mechanical, sievelike filters retain particles from the ambient water. Fluid mechanical aspects have been neglected. Suspension feeding is characterized by very low Reynolds numbers. This implies that water processing and particle retention are exclusively determined by viscous forces. Modern filtration theory can therefore be applied to hypotheses on suspension feeding involving mechanical filters. The resistance to water flow through such filters was found to correspond to pressure drops across the filters of about 0.1 to 0.4 mm H₂O in flagellates, ciliates, sponges, and ascidians; and of > 1 mm H₂O in copepods and bivalves. These theoretical pressure drops are consistent with the function as filters of ciliate membranelles, pseudopodial collars in flagellates and sponges, and ascidian mucus filters. Ciliary and flagellar water transport operate at very low pressures. The pressure drops calculated for copepod second maxillae and bivalve laterofrontal cirri seem to be incompatible with the roles as filters traditionally ascribed to these structures. Recent studies indicate that sievelike models have to be abandoned in explaining particle retention in copepods and bivalves. Particles seem to be captured by means of mechanisms that do not imply physical interception of the suspended particles. Copepods seem to have adopted mechanisms, based on viscous forces, that direct food particles in the surrounding water toward the second maxillae, which eventually capture the parcel of water that contains the particle. In the bivalve gill capture of suspended particles implies transfer from the currents passing through the gill via the interfilamentary spaces to the frontal surface currents along the filaments. Complex patterns of flow arise where the 2 systems of currents meet at the entrance to the interfilamentary spaces. The patterns are characterized by steep velocity gradients which may act on suspended particles and cause them to enter the surface currents, i.e. to be captured. It remains to be ascertained to what extent fluid mechanics operate in the capture of particles in other metazoan ciliary feeders.

INTRODUCTION

The terms 'suspension feeding' or 'filter feeding' have been coined to designate feeding in aquatic animals that have evolved special structures to process the surrounding water and to retain small suspended particles, including food particles such as phytoplankton cells. Typically, the particles are too small to be sensed and seized individually, and suspension feeding may be looked upon as the solution to the scaling problem of growing big while remaining a grazer in aquatic habitats where phytoplankton dominates primary production.

Feeding by water processing implies the exploitation of fluid mechanical principles, but the fluid mechanics of suspension feeding has remained a neglected subject (Rubenstein and Koehl, 1977; Vogel,

1981). Most hypotheses on mechanisms of suspension feeding ignore the fact that the processes are characterized by low Reynolds numbers.

The Reynolds number expresses the relation between inertial forces and viscous forces, given by the ratio av/γ , where a = linear dimension of an object, e.g. a particle; v = velocity relative to the surrounding fluid; γ = kinematic viscosity of the fluid. Movements of suspended particles at Reynolds numbers < 1 are thus dominated by viscous forces, and at very low Reynolds numbers inertial forces are insignificant. Reynolds numbers that apply to the feeding structures of suspension feeders are $\ll 1$, and the mechanisms of water processing and particle retention are thus exclusively determined by viscous forces. This implies that flow is laminar; turbulent flow cannot arise at low Reynolds numbers. Moreover, movements of particles

become independent of gravity, and Stokes law for the resistance to movements of spherical particles is thus valid: $R = 6\pi a\mu v$, where a = radius; v = velocity of the particle; μ = viscosity. These facts have great implications for hypotheses on mechanisms of suspension feeding. Most descriptions of suspension feeding imply inertial forces, and several hypotheses are explicitly based on such forces (Jørgensen, 1966; Bullivant, 1968a, b). However, application of Stokes law shows that the momentum of particles suspended in the feeding currents produced by different types of suspension feeders only suffices to move the particles a fraction of their own diameter (Strathmann, 1971; Fenchel, 1980a). Therefore, at low Reynolds numbers inertial forces cannot serve to concentrate particles, and descriptions and hypotheses that imply inertial forces in suspension feeding are thus invalid.

In suspension feeding 2 phases can usually be distinguished: One phase includes the processing of the water and the retention of particles, the other the transfer of retained particles to the mouth. The first phase basically comprises a filtration of the surrounding water, and consequently filtration theory applies. Also the second phase may be based on fluid mechanical principles, but here other types of mechanisms have been adopted, too.

FILTRATION THEORY

Filtration theory has progressed greatly during the last decades, concurrently with the increasing concern of purifying air of contaminating particles, e.g. originating from industrial processes (Davies, 1973). Filters generally operate at low Reynolds numbers, and their fluid mechanics are therefore dominated by viscous forces. The laws of fluid mechanics apply to liquids and gases which physically both are fluids. Several filtration models have been developed, especially for fibrous filters which predominate in aerosol filtration (Davies, 1973; Spielman, 1977). Filters are characterized by the efficiency with which they retain particles and the resistance they offer to the fluid flow through the filters, as expressed by the relationship between velocity of fluid flow and pressure drop across the filter. At low Reynolds numbers the relationship follows Darcy's law (Davies, 1973), the pressure drop, dp/dx , being proportional to the viscosity of the fluid, μ , and the unrestricted flow velocity, U_0 : $dp/dx = -k\mu U_0$.

The value of k depends upon the diameter of the fibers that constitute the filter, the ratio of the volume of the fibers to the volume of the filter, as well as the boundary conditions chosen for the models to predict resistance to flow. The models mostly operate with

fibers represented by cylinders that may be randomly distributed within the filter, or regularly spaced and oriented, e.g. parallel to each other.

Models have been tested experimentally, e.g. by Kirsch and Fuchs (1967a, b). These authors constructed filters that consisted of parallel, equally spaced strings of various diameters and used 95 % glycerol as a fluid. The flow fields around the fibers were visualized by means of plastic spheres, and photographed. The flow fields and drags acting on the fibers agreed closely with various theoretical models developed by Japanese authors (Tamada and Fujikawa, 1957; Miyagi, 1958; Kuwabara, 1959). At fiber (cylinder) fractions of the filters $\ll 1$ a number of models provided very similar values for the resistance to fluid flow. Table 1 shows pressure drops predicted by various models for a cylinder fraction of 0.01 by volume of the filter. The calculations have been made for 1 layer of cylinders and for a flow velocity of 0.2 cm s^{-1} , normally to the longitudinal axis of the cylinders. Such filter dimensions and flow velocities are representative for the laterofrontal cirri of the bivalve gill (see below). The values tend to be lower for models with randomly oriented cylinders,

Table 1. Theoretical pressure drops across different filter models

Δp mm H ₂ O	Orientation of fibers in models	References
1.2	Parallel, equally spaced	Tamada and Fujikawa (1957), Miyagi (1958)
1.0	Randomly oriented in plane normal to flow	Happel (1959), Spiel- man and Goren (1968)

which agrees with experiments (Kirsch and Fuchs, 1967b). But it is noteworthy how little the values differ, considering the different theoretical basis for the models. The first 3 models in Table 1 represent different approximations to the Stokes equations, whereas the last (Spielman and Goren, 1968) used another type of model.

Tamada and Fujikawa (1957) and Miyagi (1958) based their theory on the simple model of a plane row of equally spaced parallel cylinders of equal diameter. This model closely mimics filters or filter-like structures as described in several types of suspension feeders. It has therefore been chosen for evaluation of pressure drops across suspension feeding filters, expressed by the Darcy equation:

$$\Delta p = \frac{8\pi\mu U_0}{b(1 - 2 \ln \tau + 1/6 \tau^2 - 1/144 \tau^4)}$$

where $\tau = \frac{d}{b}$; d = diameter of the cylinders; b = center distance between neighbouring cylinders.

FILTER CHARACTERISTICS OF SUSPENSION FEEDING

Several groups of suspension feeders are widely assumed to retain suspended particles in the surrounding water by passing the water through filters that act as mechanical sieves. These groups include ciliates, sponges, copepods, bivalves, and ascidians. But filter feeding also occurs widespread among other taxonomic groups, from heterotrophic nanoplankton flagellates to gastropods and echinoderms.

Flagellates

The quantitative aspects of filter feeding have recently been dealt with in the 2 microflagellates, *Monosiga* sp. and *Actinomonas mirabilis* (Fenchel, 1982a, b). *Monosiga* sp. is a small choanoflagellate, 3 to 3.5 μm in diameter. The smooth flagellum, 5 to 6 μm long, is surrounded by a collar that consists of 18, 0.1- μm thick pseudopodia, spaced about 0.3 μm apart. *Actinomonas mirabilis* is of obscure taxonomic position, but it is usually placed among the heliozoans. The cell is 4 to 5 μm in diameter, and it carries a hispid, 16 μm long flagellum surrounded by a collar of 10 to 12, 6 μm long and about 0.2- μm thick pseudopodia. The distances between adjacent pseudopodia increase

from about 1 μm at the base to about 3 μm distally (Fig. 1 A and B).

Smooth flagella propel water away from the cell, hispid flagella toward the cell. In *Monosiga* sp., water therefore passes between the pseudopodia from the outside into the collar, whereas in *Actinomonas mirabilis* water passes from inside the collar to the outside. In both systems the collars presumably act as filters that intercept particles down to bacterial sizes. Fenchel calculated the filtration rates from the thrust of the flagellum, the swimming velocity and dimensions of the collar filters, and as maximum volumes of water cleared of bacteria. The different approaches were in good agreement. From the values obtained it can be calculated that in *A. mirabilis* the water passes the collar at an unrestricted velocity of about $220 \mu\text{m s}^{-1}$; this corresponds to a pressure drop of about 0.08 mm H_2O . In *Monosiga* sp. the flow velocity is about $28 \mu\text{m s}^{-1}$, corresponding to a pressure drop of 0.15 mm H_2O (Table 2). The higher flow velocity through the filter of *A. mirabilis* is correlated with the greater spacing of the pseudopodia in the collar.

Ciliates

Primitive gymnostome ciliates are basically raptorial macrophages (Fenchel, 1980a), but suspension feeding

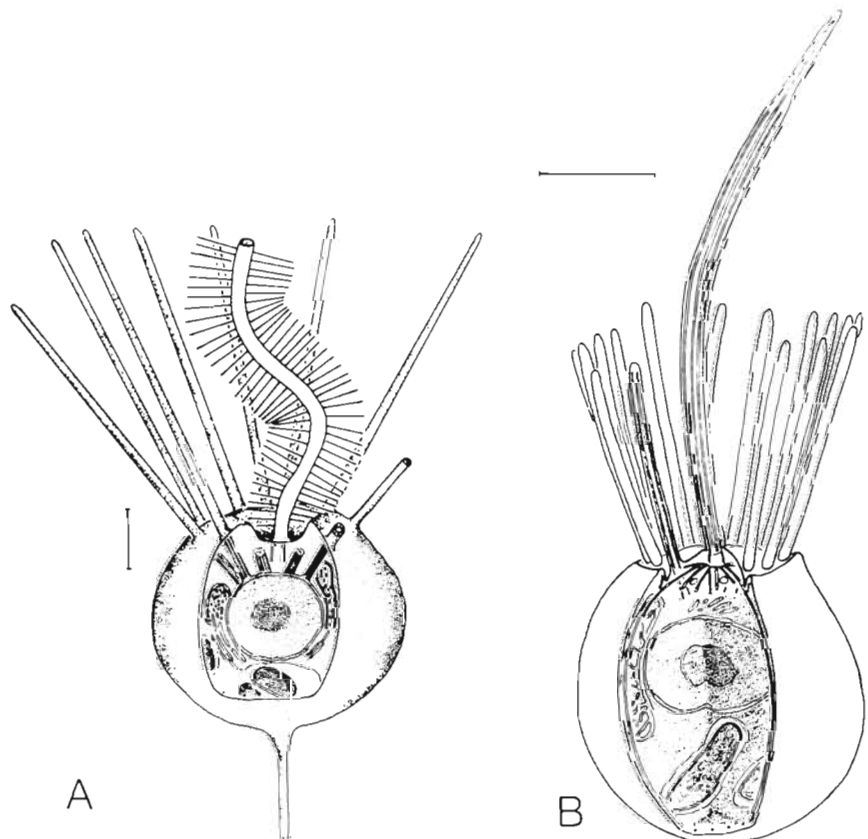

Fig. 1. Flagellates. Heliozoan? *Actinomonas mirabilis* (A) and choanoflagellate *Monosiga* sp. (B). Cell structures, nucleus, mitochondriae, Golgi apparatus, and food vacuoles. In *A. mirabilis* pseudopodia forming the collar are supported by microtubules which originate from the nuclear membrane. Scales: 1 μm . (After Fenchel, 1982a)

Table 2. Filter characteristics in suspension feeders

Taxonomic group and species	Structure	$\frac{d}{b}$	U_o mm s^{-1}	Δp mm H_2O	Re	References
Flagellates						
<i>Monosiga</i> sp.	Pseudopodial collar	0.25	0.03	0.15	10^{-6}	Fenchel (1982a, b)
<i>Actinomonas mirabilis</i>		0.1	0.22	0.08	10^{-5}	
Ciliates						
<i>Cyclidium</i> sp.	Paroral membrane	0.4	0.05	0.3	10^{-4}	Fenchel (1980b)
Sponges						
<i>Haliclona permollis</i>	Choanocyte collar	0.5	0.003	0.1	10^{-7}	Reiswig (1975)
Copepods						
<i>Calanus finmarchicus</i> , <i>C. hyperboreas</i>	Setae	0.2	10	2.1	10^{-2}	Koehl and Strickler (1981) (<i>Eucalanus pilatus</i>)
Bivalves						
<i>Mytilus edulis</i>	Laterofrontal cirri	0.10	2	1.2	10^{-4}	Jørgensen (1981a)
<i>Geukensia demissa</i>		0.16	2	≥ 3		Wright et al. (1982)
Ascidians						
<i>Ciona intestinalis</i>	Mucus net	0.11	0.2	0.4	10^{-4}	Flood and Fiala-Medioni (1981)
<i>Asciella aspersa</i>		0.10	0.2	0.4		Jørgensen (1949); Randløv and Riisgård (1979); Roule (1884)

d Diameter of fiber; b center distance between fibers; U_o unrestricted flow velocity; Δp theoretical pressure drop across filter; Re Reynolds number

has been widely adopted among the ciliates. The feeding mechanisms vary in detail, but they are based on filtration of the surrounding medium (Fig. 2). Ciliary organelles generate water currents that are forced through ciliary filters, whereas suspended particles are

deflected toward the mouth. The particles are concentrated in front of the cytostome and phagocytized (Fenchel, 1980a, b). The different species of suspension feeding ciliates have specialized on particles within well-defined size spectra. The optimal sizes range

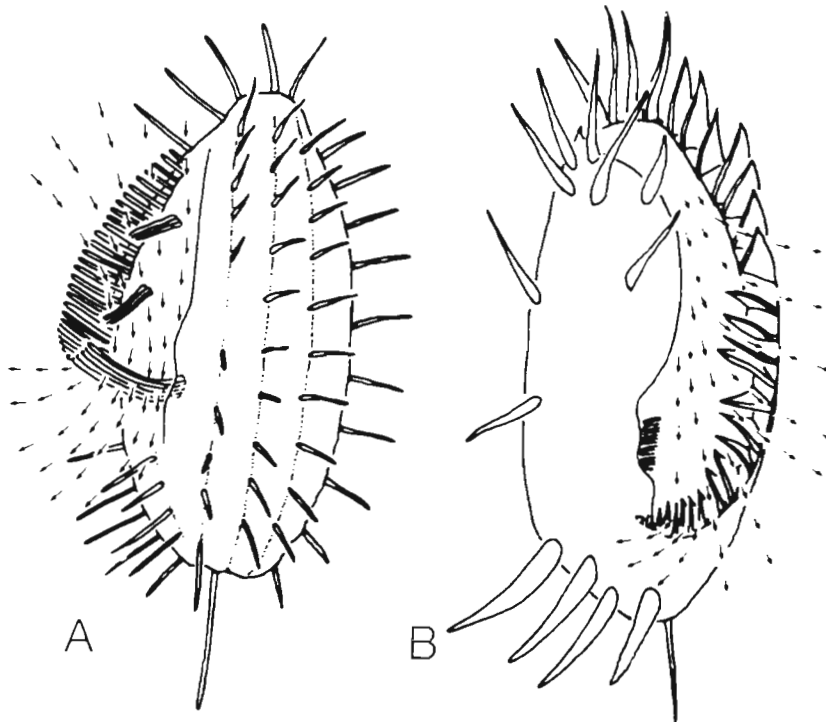

Fig. 2. Ciliates. Feeding currents in the hymenostome ciliate *Cyclidium* sp. (A), seen from left (length ca. 20 μm). Feeding currents in the spirotrich ciliate *Euplotes moebiusi* (B), seen from ventral right (length ca. 35 μm). (After Fenchel, 1980b)

from bacterial size, less than 1 μm in diameter, to phytoplankton cells, and even to large prey organisms. There is close agreement between the optimal size of food particles and the porosity of the filters (Fig. 3).

The rates at which the different types of suspension feeding ciliates clear the water of particles vary with

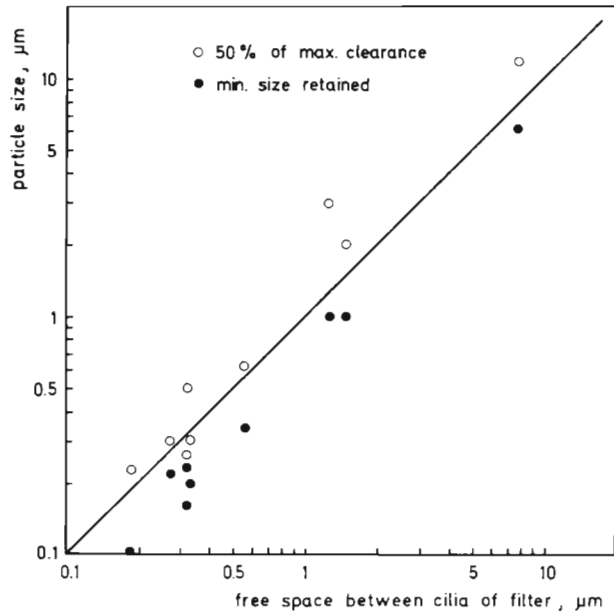

Fig. 3. Ciliates. Relationship of free space between cilia assumed to retain particles and size of particles retained with an efficiency of 50 %, and minimum size retained, in 9 species of ciliates. (After Fenchel, 1980a)

optimum food size. There is a striking similarity in the relationship between the porosity of the filters and their resistance to water flow on one side and the relationship between optimal particle size and rates of water filtration on the other (Fig. 4). The rates at which

the surrounding water is cleared of particles may thus be determined by the filter resistance. This resistance could be calculated in some species in which the filter constitutes a row of parallel cylinders, such as the paroral membrane of the hymenostome ciliate *Cyclidium* sp. (Fig. 2). The pressure drop across the filter of feeding animals amounted to about 0.3 mm H_2O (Table 2).

Sponges

The sponges are unique among suspension feeders in having the entire body differentiated as an organ of feeding. They are also unique in feeding by means of choanocytes, i.e. by a protozoan feeding mechanism, as adopted by the choanoflagellates. The basic functional features are the same in all classes of sponges. Water enters the sponge through numerous ostia, passes through branching canals to the choanocyte chambers, and leaves through exhalant canals that merge into one or more oscula. Bidder (1923) measured dimensions and cross sectional areas of the various parts of the aquiferous system and made fluid mechanical calculations in the calcareous sponge *Leuconia aspera*, presumably the first study of its kind in suspension feeding.

Reiswig (1975) extended measurements and calculations to 3 species of demosponges, *Haliclona permollis*, *Halichondria panicea*, and *Microciona prolifera*. The patterns of cross sectional areas, and thus the rates of water flow, at the different levels of the aquiferous system, from the ostia to the oscula, were remarkably similar both among the 3 demosponges and between the 2 classes of sponges, Calcarea and Demospongia. The largest transectional area is through the choanocyte chambers. At this level the velocity of the water current thus reaches its minimum. The choanocyte

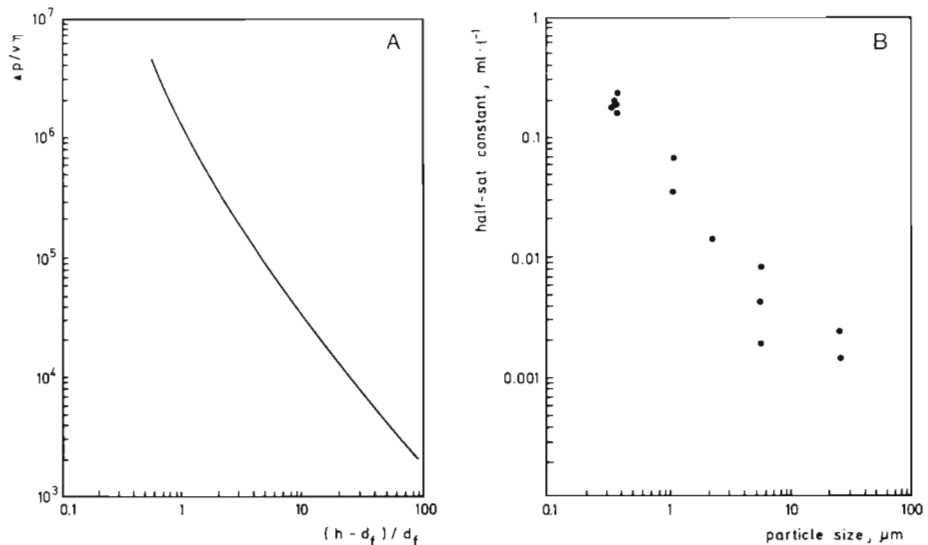

Fig. 4. Ciliates. A: pressure drop across a filter consisting of a single layer of parallel cylinders as a function of ratio between free space between cylinders and cylinder diameter. B: half-saturation constant (total particle volume l^{-1}) for ingestion of optimum-sized particles for 13 species of ciliates. (After Fenchel, 1980b)

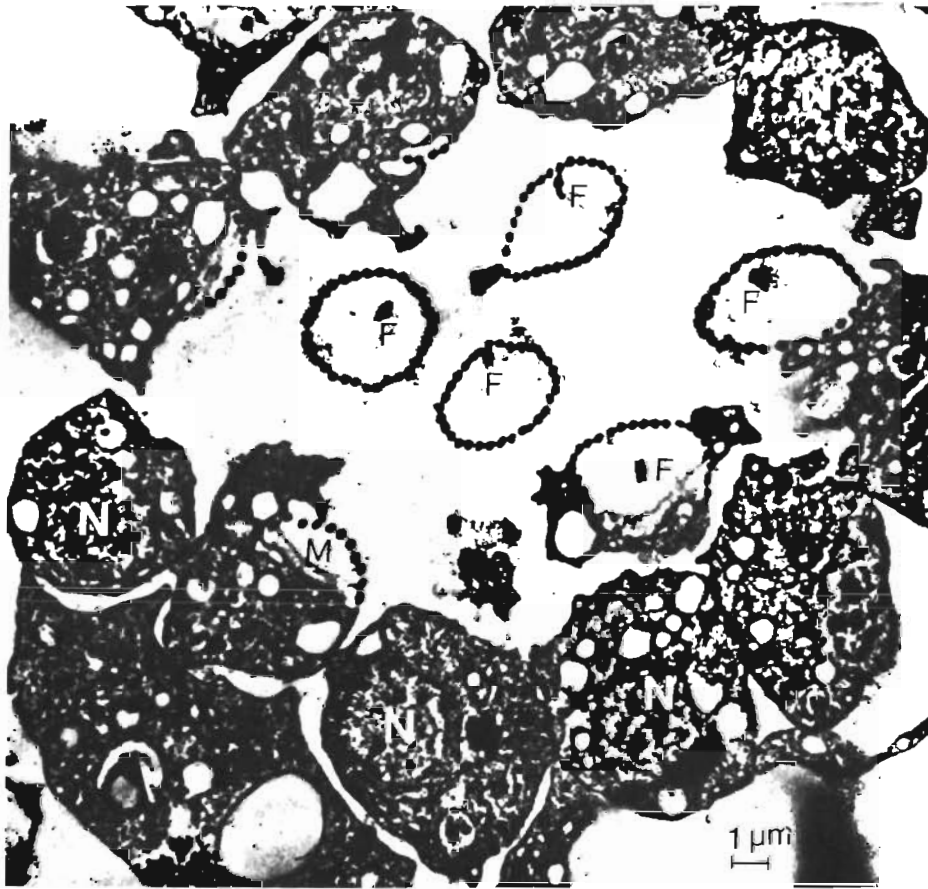

Fig. 5. Sponges. Section of whole flagellate chamber of *Spongilla lacustris*. Collars sectioned both transversally and obliquely; collar fibrils (pseudopodia) evident. N choanocyte nucleus; F flagella; M probably mucus in the bottom of the collar. (After Fjerdingsstad, 1961)

chambers drive water through the sponge by means of flagella that line the choanocyte chambers (Fig. 5). The beating flagellum draws water through the collar surrounding each flagellum. The collar consists of a circular row of about $0.13\text{-}\mu\text{m}$ thick pseudopodia, spaced at distances of about $0.13\text{ }\mu\text{m}$ (Fjerdingsstad, 1961). Reiswig (1975) provides data for the water current, number of choanocytes, and collar dimensions in *Haliclona permollis* from which it can be calculated that if all water passes the collars the unrestricted flow velocity normal to the surface of the collar is about $3\text{ }\mu\text{m s}^{-1}$. This corresponds to a pressure drop across the collar filter of about $0.1\text{ mm H}_2\text{O}$ (Table 2). Similar values probably apply to sponges generally.

Copepods

In suspension feeding calanoid copepods the second maxillae are filterlike structures composed of setae with sidebranches, the setules. The second maxillae were generally believed to act as sieves, the efficiency of particle retention being determined by the spacing

of the setae and setules (Nival and Nival, 1976; Frost, 1977; Rosenberg, 1980). However, recently high-speed motion pictures showed that dyed water around feeding calanoid copepods did not pass between the setae of the second maxillae (Fig. 6). The second maxillae thus do not strain a feeding current of food particles, but rather act to create water currents that help to bring food particles within reach (Koehl and Strickler, 1981; Paffenhöfer et al., 1982).

Calculations showed that if the second maxillae should filter the volume of water cleared of particles, at a velocity of the water current of 1 cm s^{-1} , the maxillae would have to be 6 times larger than they actually are (Koehl and Strickler, 1981). The resistance to water flow between the setules at a flow velocity of 1 cm s^{-1} can be estimated from the setule diameter and the distances between neighbouring setules. In *Calanus finmarchicus* and *C. hyperboreas* the ratio between diameter and center distance was found to be about 0.2 (unpubl. own observations), and the pressure drop about $2\text{ mm H}_2\text{O}$ (Table 2). At the velocity needed in order to filter the entire volume of water cleared of particles the pressure drop would run six times higher.

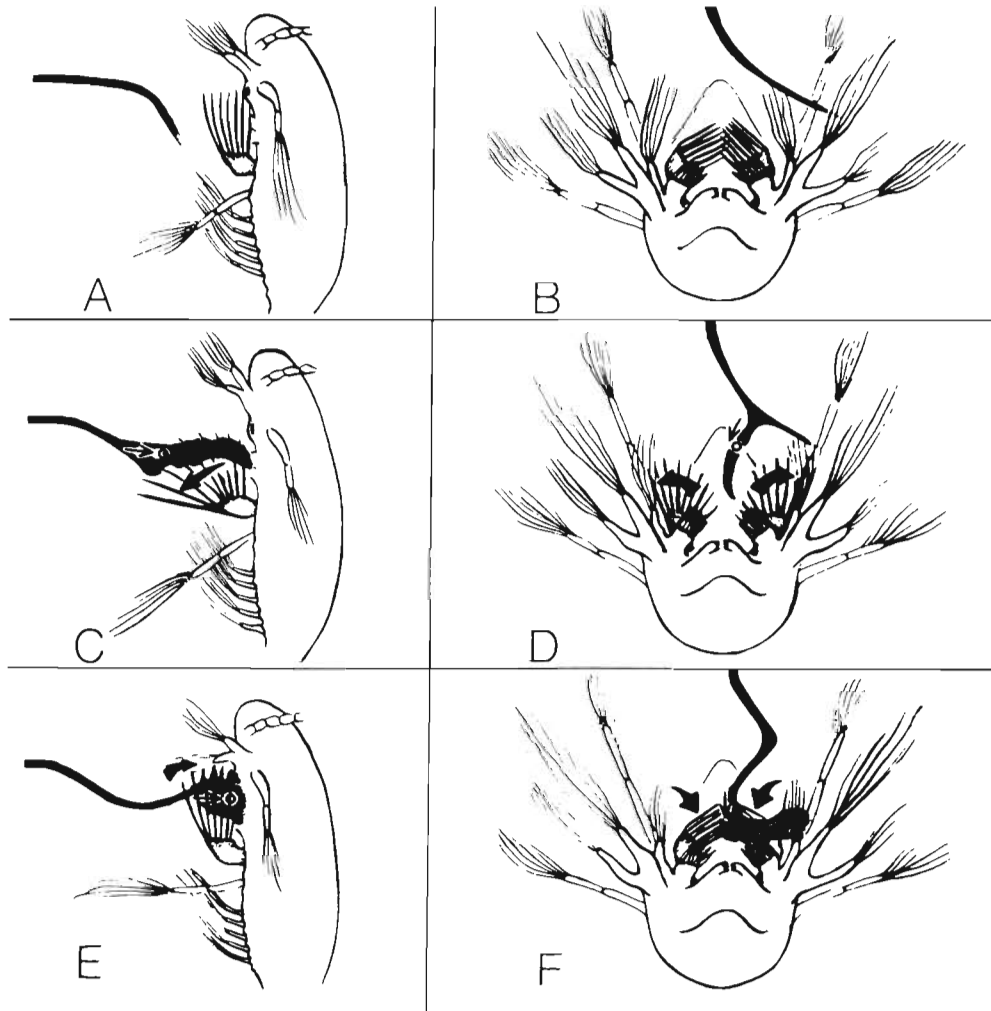

Fig. 6. Copepods. Diagrams traced from high-speed films of a feeding *Eucalanus pileatus*. Black streaks are dye streams from micropipette. Heavy arrows: movements of second maxillae (and of a first maxilla in F). Small circles: positions of algae; fine arrows: their movements as observed during similar appendage motions in other frames of films. In first column, copepod is viewed from left side; first maxilla has been left off for clarity. In second column, copepod is viewed from its anterior end. Feeding currents bypass second maxillae (A-B) until an alga nears them. Alga is captured by an outward fling (C-D) and an inward sweep (E-F) of second maxillae. (After Koehl and Strickler, 1981)

Bivalves

A vast literature deals with the function of the bivalve gill in filter feeding. Most authors ascribe a central role to the laterofrontal cirri as sieves that retain particles from the interfilamentary currents (Dral, 1967; Moore, 1971; Owen, 1974; Ribelin and Collier, 1977). These hypotheses of the laterofrontal cirri acting as sieves are based on the filterlike structure of the cirri. Branching cilia along both sides of the cirri constitute rows of parallel cylindrical fibers, spaced about $1\ \mu\text{m}$ apart (Fig. 7). It seems, however, that the resistance of the filters prevents any significant flow of water between the branching cilia. In *Mytilus edulis* the resistance across the laterofrontal cirri at unrestricted flow velocities corresponded to a

pressure drop of about $1.3\ \text{mm H}_2\text{O}$ (Jørgensen, 1981a). The calculations were based on the assumptions that the cylinder (cilia) diameter was $0.2\ \mu\text{m}$ and flow velocity was $0.16\ \text{cm s}^{-1}$. More realistic values are $0.13\ \mu\text{m}$ for the branching cilia (Owen, 1974), and $0.2\ \text{cm s}^{-1}$ for the unrestricted flow velocity in mussels that feed under optimal conditions (Kjørboe et al., 1980). The ratio between cylinder diameter and center distance of the laterofrontal cirri in *M. edulis* is thus 0.1, and the theoretical pressure drop $1.2\ \text{mm H}_2\text{O}$. In other species of bivalves even higher pressure drops may obtain, e.g. $\geq 3\ \text{mm H}_2\text{O}$ in *Geukensia demissa* (Table 2). These pressure drops are calculated for resting cirri at the end of the recovery stroke. During the effective stroke the velocity of the distal ends of the cirri should be added to the water flow velocities, which may double the

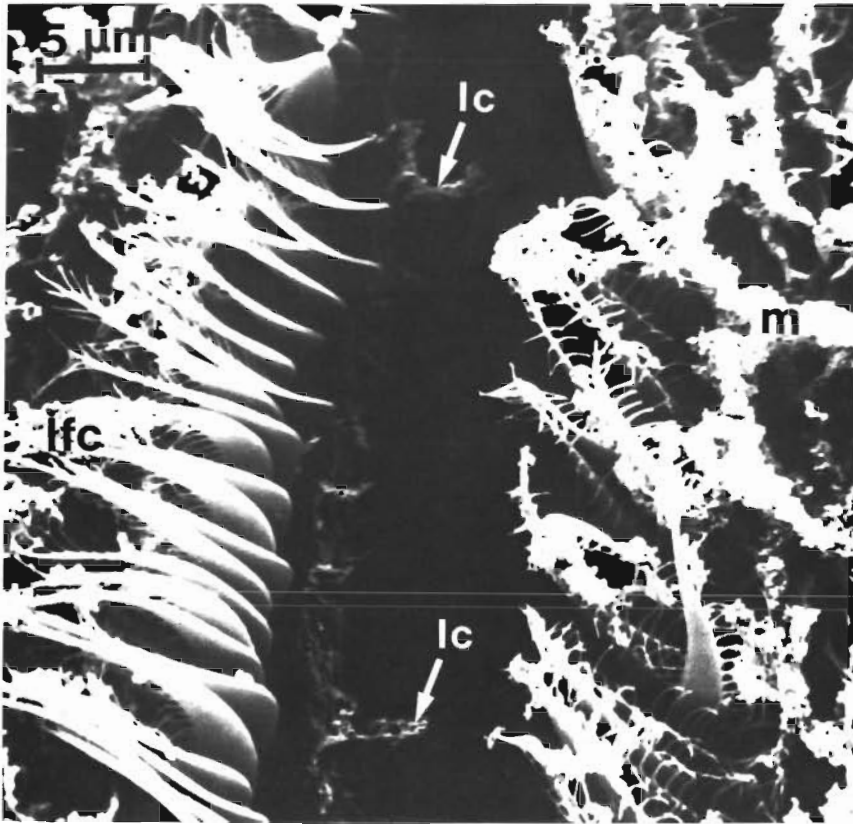

Fig. 7. Bivalves. Scanning electron micrograph of gill fragment of *Mytilus edulis*, surface view. On left filament laterofrontal cirri are inactive and bend over the frontal surface of the filament. On right filament cirri are beating, bridging over the interfilamentary space in their straight phase. Branching of constituent cilia is clearly seen. Lateral cilia are inactive, pointing obliquely upwards. Numerous curling mucus threads adhere to the laterofrontal cirri and frontal cilia. lc lateral cilia; lfc laterofrontal cirri; m mucus. (After Jørgensen, 1975)

pressure drops. The maximum pressure the bivalve gills are capable of producing amounts to 4 to 5 mm H₂O (Foster-Smith, 1978). At unrestricted water flow the pressures are much lower. Foster-Smith (1976) measured the total pressure drop across the gill of *M. edulis* to be 0.1 to 0.3 mm H₂O, but it may actually be about 0.7 mm H₂O (Jørgen Gomme, pers. comm.). Presumably, therefore, the water currents mainly bypass the laterofrontal cirri, which instead of filtering the water currents move water. The beating cirri seem to contribute to the water currents along the frontal surface of the gill filaments (Jørgensen, 1981a).

The laterofrontal cirri thus seem to act as oarlike structures, and the question arises as to the resistance they offer to the water currents entering the interfilamentary spaces. The flow of water through the bivalve gill is sensitive to an increase above the normal resistance (Foster-Smith, 1978), and the flow stops at pressure heads of 4 to 5 mm H₂O. The resistance of the laterofrontal cirri may be evaluated by studying the effect of removing the cirri from the entrance to the interfilamentary space. This can be achieved by adding serotonin to the water, which strongly reduces the angle of beat of the cirri (Fig. 8). This elimination of the resistance to flow exerted by the laterofrontal cirri does not affect the through current (Jørgensen, 1975; Tom Knudsen, pers. comm.). It thus seems that the latero-

frontal cirri only offer negligible resistance to the water flow through the bivalve gill, even when the water currents have to bypass the structures when entering the interfilamentary spaces. This conclusion is supported by the finding that the rate of water transport is similar in *Mytilus edulis* and *Geukensia demissa* (Kuenzler, 1961; Møhlenberg and Riisgård, 1979; Jordan and Valiela, 1982) despite the great difference in filter resistance of the laterofrontal cirri.

A mechanism for filtration not implying cirral sieves is discussed below.

Ascidians

Suspension feeding by means of filtration through netlike structures is of widespread occurrence (see Jørgensen, 1966). In several groups the filaments of the nets consist of mucus threads, e.g. in several groups of gastropods and in tunicates. Mostly filtration through mucus nets has developed in connection with ciliary feeding, e.g. in the ascidians. The structure of ascidian pharyngeal mucus nets has recently been investigated with transmission and scanning electron microscopy (Flood and Fiala-Medioni, 1981). The nets are built of longitudinal and transverse filaments that form rectangular meshes. In the fixed state of the nets the mesh dimensions varied between species from 0.2 to 0.5 μm



Fig. 8. Bivalves. Serotonin-stimulated gill fragment of *Mytilus edulis*. Laterofrontal cirri are maximally bent over frontal surfaces of filaments, pointing toward the tips of filaments. Activated bands of lateral cilia are organized in metachronal waves. lc lateral cilia in effective stroke; lfc laterofrontal cirri. (After Jørgensen, 1975)

in width and 0.5 to 2.2 μm in length, whereas the filaments were 10 to 40 nm thick. Calculations of the resistance of the nets to water were made separately for the longitudinal and transverse filaments, and the sum of the resistances has been used as representative of the net. The velocity of water flow through the nets was estimated from the rate of water flow through the pharynx (Jørgensen, 1949; Randsløv and Riisgård, 1979) and the area of the pharynx wall (Roule, 1884). The unrestricted water flow at the level of the mucus net was calculated to be 0.2 mm s^{-1} in *Ciona intestinalis*, and it is probably similar in *Ascidella aspersa* (Randsløv and Riisgård, 1979). The resistance was found to correspond to a pressure drop of about 0.3 to 0.4 $\text{mm H}_2\text{O}$ (Table 2). This corresponds to the pressure drop Foster-Smith (1976) measured directly from the inhalant to the exhalant siphon in *C. intestinalis*.

FLUID MECHANICAL MECHANISMS OF PARTICLE RETENTION

Previous hypotheses on suspension feeding in copepods and bivalves failed because they ignored the fluid mechanical consequences of the low Reynolds numbers that characterize the mechanisms. Presumably sievelike models have to be abandoned in ex-

plaining particle retention in both copepods and bivalves. Particles seem to be captured by means of fluid mechanical mechanisms that do not imply physical interception of the suspended particles.

Copepods

According to Koehl and Strickler (1981) calanoid copepods 'propel water past themselves by flapping their feeding appendages and actively capture small parcels of the water that contain food particles by flinging and closing their second maxillae' (Fig. 6). The second maxillae thus act as sieves only in the final stage of the feeding process, when water is squeezed from the parcel that contains the food particle. The copepods were observed to flap their feeding appendages independently, presumably in order to direct suspended particles toward the second maxillae. The copepods thus fed selectively on individual food particles that might be sensed by mechanical or chemical cues. Feeding on large particles in copepods is therefore basically raptorial, but the mechanisms applied are of fluid mechanical nature, based on viscous forces at the low Reynolds numbers of 10^{-2} to 10^{-1} . It remains to be elucidated how copepods feed on particles that are too small to be handled individually.

Bivalves

The gills of suspension feeding bivalves produce 2 types of water currents, the through current which passes between the filaments, and the surface currents which run along the frontal surface of the filaments and further along the ventral and dorsal margins of the gills to the mouth. Capture of suspended particles implies their transfer from the through current to the frontal surface currents along the filaments. When particles in viscous flow at low Reynolds numbers are exposed to shear forces, the particles tend to migrate perpendicularly to the streamlines (Cox and Hsu, 1977; Drew, 1978; Leal, 1980). Such shear arises at interfaces between laminar currents, e.g. those established where through currents and surface currents meet at the entrance to the interfilamentary spaces of the mussel gill (Fig. 9). It was therefore suggested that the shear forces were responsible for the transfer of sus-

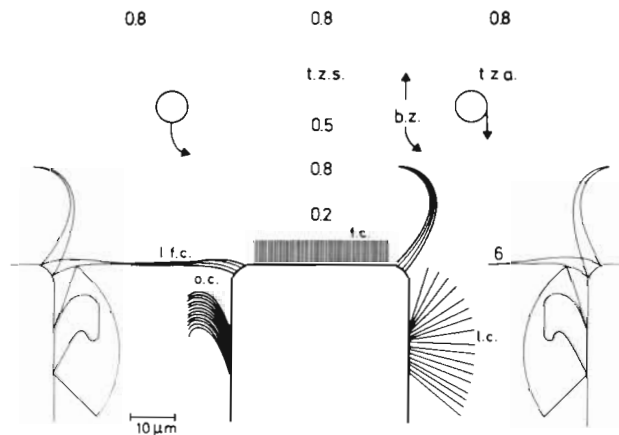

Fig. 9. Bivalves. Diagram of cross section of gill surface indicating patterns of water currents around frontal surface of an individual filament; filibranch bivalve *Mytilus edulis*. Direction of current flow along frontal surface of filament is perpendicular to plane of paper. Figures indicate velocities (mm s^{-1}), directly measured in surface current or calculated from estimated cross section areas available for through currents; unrestricted flow rate: 0.8 mm s^{-1} . Right: arrow symbolizes forces that cause a suspended particle to move perpendicularly to flow direction when particle enters the velocity gradients established within the boundary zone between through current and surface current. Left: arrow indicates effect of the forces in changing the direction of movement toward the surface current. Lateral cilia (l.c.) produce through current; on the right they are shown during effective stroke, on the left during recovery stroke. A laterofrontal cirrus (l.f.c.) is shown on the left in resting position at end of recovery stroke; on the right, at end of effective stroke. Frontal cilia (f.c.) and laterofrontal cirri produce surface current. b.z. boundary zone between accelerating through current and surface current; o.c. zone of oscillatory currents produced by oscillatory movements of the enveloping surface of the tract of active lateral cilia; t.z.a. zone transitional to accelerating through current; t.z.s. zone transitional to surface current. (After Jørgensen, 1981a)

pended particles from the through current into the surface currents, i.e. capture of the particles (Jørgensen, 1981a).

In the first outline of the hypothesis it was suggested that the unidirectional components of the through current and the surface current were primarily responsible for the particle capture. Preliminary calculations suggest, however, that this simple model could not explain the efficiency with which small suspended particles are transferred from the through current to the surface currents (P. Scheel Larsen, pers. comm.). It is suggested that the oscillatory currents produced by the band of lateral cilia play an important role in the mechanism of particle retention in the bivalve gill (Jørgensen, 1981a). The currents produced by these bands have therefore been studied in some detail (Jørgensen, 1982).

The band of lateral cilia is about $10 \mu\text{m}$ broad and consists of cilia arranged in rows that run obliquely across the band, spaced $0.2 \mu\text{m}$ apart. This dense spacing and the viscous forces acting between the cilia practically excludes water from being transported between the beating cilia, according to calculations only a few percent of the through current. The bands of lateral cilia thus act upon the water mainly through the complex three-dimensional oscillatory motions of the enveloping surface of the metachronal wave produced by the beating cilia. The oscillating surface generates flow patterns that are characterized by the gradual transition from oscillatory currents near the surface to the rectified interfilamentary through current distally to the ciliary tips during the effective stroke (Fig. 10). The counter currents associated with the phase of the recovery stroke of the metachronal wave may be an integral part of the fluid mechanical mechanism for particle retention. However, further experimental and theoretical investigations are needed to evaluate the capacities and relative importance of the various components of the through currents and surface currents in capturing suspended particles. The theory of motions of small particles in low-speed laminar flow systems has developed greatly in recent years (Spielman, 1977; Leal, 1980). But no theory deals with transfer of particles between such complex flow systems as those encountered in the gills of suspension feeding bivalves and in other types of ciliary suspension feeders.

CILIARY BAND FEEDING HYPOTHESES

Feeding by means of ciliary bands is widely distributed among metazoan suspension feeders. Two types of feeding can be distinguished. In one type, upstream retention, particles are retained above the current-generating band of cilia. In the other type, downstream

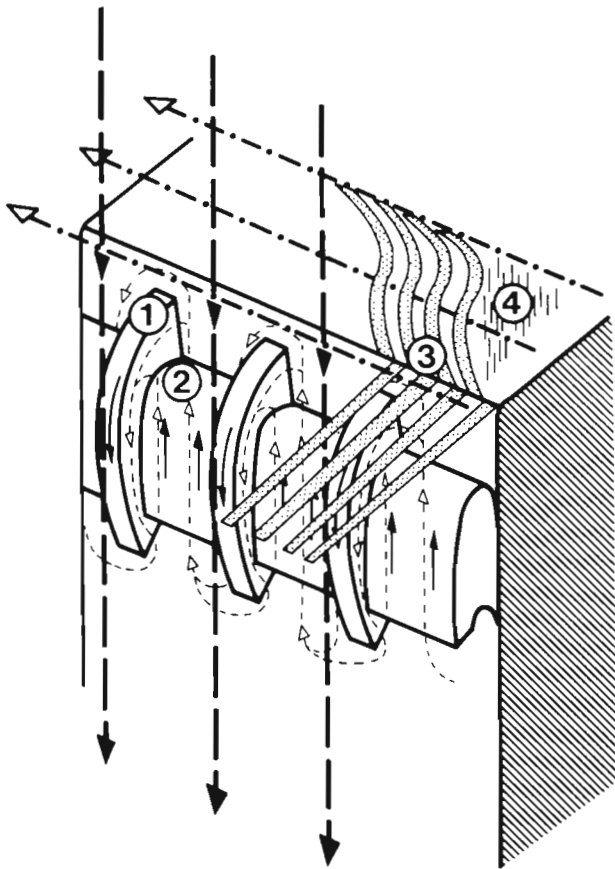

Fig. 10. Gill filament showing ciliary tracts and water currents. 1 phase of effective stroke of metachronal wave of band of lateral cilia; 2 phase of recovery stroke of the wave; 3 tract of laterofrontal cirri alternatingly shown during resting phase crossing the interfilamentary space, and at end of effective stroke normal to the frontal filament surface; 4 band of frontal cilia. Heavy dashed arrows: interfilamentary through current; heavy dot-and-dash arrows: surface current along frontal surface of the filaments. Light solid arrows: directions of movements of the surface enveloping the metachronally beating band of lateral cilia; light broken arrows: oscillating water currents produced by metachronal wave which moves toward the left. (After Jørgensen, 1982)

retention, particles are collected below the band. Upstream retention has been described in most lophophorate ciliary feeders, including bryozoans, brachiopods, and phoronids (Bullivant, 1968a; Strathmann, 1973), as well as in planktonic larvae of echinoderms and hemichordates (Strathmann 1971, 1975; Strathmann and Bonar, 1976). Upstream retention is correlated with the presence of only a single band of simple cilia responsible for both water transport and particle retention (Strathmann, et al., 1972).

Downstream retention of particles has been described in lophophorate endoprocts, rotifers, sabellid polychaetes, molluscan veligers, and other groups (Lewis, 1968; Nielsen and Rostgaard, 1976; Strathmann et al., 1972; Strathmann and Leise, 1979). Down-

stream particle retention often involves 2 opposing bands of cilia, of which the current-generating first band usually carries longer cilia than the opposing second band.

The retention of particles in ciliary feeders is mostly described in general terms that reflect a lack of deeper understanding of the mechanisms of retention. However, during the last decade Strathmann and co-workers have made important contributions to the analysis of the mechanisms. The pattern of motion of particles and cilia were studied by means of high-speed

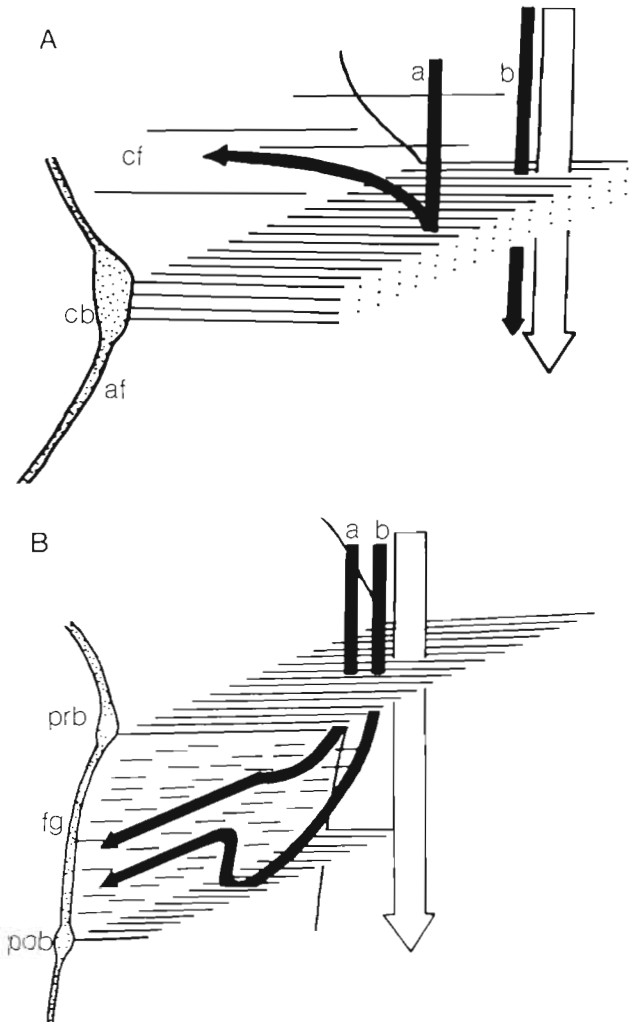

Fig. 11 Clearance of particles by ciliated bands. (A) Single band of cilia with upstream collection of particles; echinoderm pluteus larva. a larva is feeding, and ciliated band (cb) passes particles back to circumoral field (cf); b larva is not feeding, and particles pass through band of cilia with the water current produced by the cilia (white arrow). (B) Two opposed bands of cilia with collection of particles in a food groove (fg), e.g. rotifer and trochophore. a particles are brought directly into food groove by preoral band of cilia (prb); b particles are first carried to the postoral band (pob), which then conveys them to the food groove. (After Strathmann et al., 1972)

cinofilms. The feeding mechanism that collects particles upstream is referred to as the single band system. The other type is termed the opposed band system (Fig. 11A, B). In single band feeding, suspended particles are observed to stop at the ciliary band and reverse their direction (Fig. 11A). This pattern of particle movement is described as being correlated with reversal of the ciliary beats. It is stated that when a particle in the water current passing the band of cilia is overtaken by a cilium in its effective stroke the particle triggers a reversal of beat of the contacted cilium and neighbouring cilia. The cilia in the reversed beat push the particle back to the upstream side of the band (Strathmann et al., 1972; Strathmann, pers. comm.). When the animals do not feed the band continues to produce the current of water, but particles pass through the band of cilia with the water (Fig. 11A).

The opposed band system is shown diagrammatically in Fig. 11B. It is suggested that suspended particles are concentrated when they are overtaken by the preoral cilia in their effective stroke, whereas the recovery stroke may act to draw the particles into the food groove, perhaps in cooperation with the current generated by the postoral cilia (Strathmann et al., 1972; Strathmann and Leise, 1979). The fluid mechanics of the single band and opposed band feeding hypotheses remain to be finally elucidated.

FLUID MECHANICS OF TRANSFER OF CAPTURED PARTICLES TO THE MOUTH

Ciliary suspension feeders transfer particles suspended in the surrounding water into ciliary surface currents leading to the mouth. Transport of particles suspended in surface currents has been described by several authors (e.g. Gray, 1928, 1929; Nicol, 1931; Gosselin and O'Hara, 1961; Strathmann et al., 1972; Owen and McCrae, 1976). The literature on transport of particles in ciliary currents usually takes the process for granted, without mentioning that such transport requires a physical explanation. When it is realized that forces are needed to prevent the captured particles from escaping the surface currents it is suggested that mucus serves the purpose by binding the particles (Yonge, 1935; Morton, 1967). Ciliary feeding has therefore widely become synonymous with mucociliary feeding (for references, see Jørgensen, 1966). Fluid mechanical forces do, however, exist that tend to maintain particles in suspension within laminar flow systems, such as ciliary surface currents of the bivalve gill and other types of suspension feeders (Jørgensen, 1981b). Particles that move along a wall in laminar flow are exposed to viscous forces that produce migration in opposite directions, toward the wall and toward

the region of highest flow velocity, resulting in an equilibrium distance from the wall (Ho and Leal, 1974; Cox and Hsu, 1977). The forces have been calculated for rigid spheres in flow systems parallel to solid boundaries. They therefore do not directly apply to particle flow in ciliary currents, for which no theory yet exists. However, the effects of the forces can be directly observed in the fact that suspended particles in the ciliary currents remain within these currents, but disperse as soon as they leave the current (Jørgensen, 1976, 1981b). The strength of the forces can be appreciated from the observation that they prevent swimming flagellates (10 μm *Tetraselmis*) from escaping the ciliary surface currents of the bivalve gill (Jørgensen, 1976).

DISCUSSION AND CONCLUSIONS

According to modern filtration theory the resistance to water flow through the filters described in different types of suspension feeders corresponded to pressure drops across the filters that varied from about 0.1 to 0.4 mm H₂O in flagellates, sponges, ciliates, and ascidians to > 1 mm H₂O in copepods and bivalves. These theoretical pressure drops are consistent with the function as filters of the flagellate and choanocyte collars, the ciliate membranelles, and the ascidian mucus filters. The pressure drops calculated for copepod second maxillae and bivalve laterofrontal cirri seem inconsistent with a function as filters in the feeding mechanisms of these groups of suspension feeders. The 2 structures are surrounded by areas of lower resistance through which the flow may pass. This would leave the fluid inside the filterlike structures almost at rest, and thus strongly reduce the actual pressure drop across the structures. When moving, the structures will thus primarily act to produce water currents. Feeding in copepods and bivalves therefore seem to imply fluid mechanical mechanisms rather than filters that act as sieves.

There are striking similarities between the functioning of the bivalve gill and that of the single band system as described by Strathmann (1973): (1) Both single band system and bivalve gill retain particles on the upstream side of the water transporting cilia. (2) Single band system and bivalve gill can be retentive or non-retentive, with no obvious change in the appearance of the ciliary systems, and independently of the presence or absence of special cilia or cirri that have traditionally been ascribed straining functions. (3) Both systems become non-retentive in disturbed animals. (4) In the single band system particles have been described to perform characteristic 'jumping' movements on the frontal surface of the filaments or ten-

tacles connected with the capture of the particles (Strathmann, 1973). Similar jumping of particles has been observed on the surface of bivalve gills, also on gills that lack laterofrontal cirri (Jørgensen, 1975, 1976). Strathmann correlates jumping with ciliary reversals, Jørgensen with local fluid currents produced by the metachronal wave of the band of lateral cilia. (5) Both the metazoan single band system and the lateral cilia of bivalve gill filaments consist of simple cilia arranged in bands that beat in diaplectic metachronism.

The major difference is in interpretations of the mechanism of particle capture which according to Strathmann is based on ciliary reversal. Particle capture by ciliary reversal of the lateral cilia has also been suggested for the bivalve gill (Orton, 1912, p. 466) but this has not been confirmed. It is noteworthy that in spirotrich ciliates, Fenchel (1980a) describes a single band mechanism in which the ciliary band both propel water and capture particles on the upstream side, without involving ciliary reversal (Fig. 2).

Downstream particle capturing mechanisms are usually described in unspecific terms. It has been suggested (Jørgensen, 1981a) that metazoan ciliary mechanisms for water processing and particle capture may generally be of fluid mechanical nature, based on migration of particles across stream lines from the passing currents into surface currents, under the influence of viscous forces that remain to be defined.

Ciliary suspension feeding by means of filters that act as sieves presumably imply fluid mechanical constraints of ecological consequences. This is well illustrated in the ciliates (Fenchel, 1980b). The rates at which filter feeding ciliates, as well as other suspension feeders, are capable of clearing the surrounding water of food particles determine the concentrations of food particles that are needed in order to support the populations. This capacity for water processing is low in ciliates adapted to feed on particles of bacterial size, correlated with the high flow resistance of the filter, whereas the capacity is high in ciliates adapted to feed on phytoplankton-sized particles. The distribution of ciliates in nature agrees well with the predictions that can be made about food particle concentrations required to sustain the ciliate populations. Ciliates adapted to feed on bacteria require bacterial concentrations of 10^7 to 10^8 ml⁻¹. They are, therefore, restricted to environments rich in bacteria, and they are excluded from open-water habitats with bacterial concentrations of 10^5 to 10^6 ml⁻¹. The ciliates that populate oceanic environments are those with porous filters optimized to retain phytoplankton-sized food particles.

Fluid mechanical constraints thus seem to prevent ciliates from exploiting the bacterioplankton of open

waters. This food source is, however, available to sponges that filter the water through filters of high resistance but at low pressures. This has become possible at the low flow velocities through the filters, some few $\mu\text{m s}^{-1}$, as compared with ≥ 1 mm in other groups of suspension feeders that exploit the food resources of the open waters.

According to Leal (1980), 'the motion of small particles in a viscous fluid at low Reynolds number is one of the oldest classes of problems in theoretical fluid mechanics, dating at least to Stokes's (1851) analysis of the translation of a rigid sphere through an unbounded quiescent fluid at zero Reynolds number'. Suspension feeding is capturing of particles in Stokes flow. This fact was long neglected by biologists who investigated mechanisms of suspension feeding. Observations were interpreted in terms that apply to a physical environment familiar to the investigators, dominated by inertial forces. A more realistic approach to suspension feeding is only about to emerge.

Theoretical fluid mechanics was slow to evolve. Practical implications served as impetus to the development of filtration theory, which turned out to be useful to characterize filter feeding. However, suspension feeding encompasses more than filtration of water through filters that approximate rows of parallel cylinders. It involves highly complex fluid mechanical processes, including migration of particles across steep velocity gradients and oscillatory flow pattern. For such problems fluid mechanical analyses are still lacking.

It seems that the theoretical analysis of the fluid mechanics adapted in different types of ciliary suspension feeders may be of mutual benefit to fluid mechanics and biology. The theoretical solutions may even have technological perspectives by the disclosing of mechanisms that concentrate particles in non-clogging filters.

LITERATURE CITED

- Bidder, G. P. (1923). The relation of the form of a sponge to its currents. *Quart. J. microb. Sci.* 67: 293-323
- Bullivant, J. S. (1968a). The method of feeding of lophophorates (Bryozoa, Phoronida, Brachiopoda). *N. Z. J. mar. Freshwat. Res.* 2: 135-146
- Bullivant, J. S. (1968b). A revised classification of suspension feeders. *Tuatara* 16: 151-160.
- Cox, R. G., Hsu, S. K. (1977). The lateral migration of solid particles in laminar flow near a plane. *Intern. J. Multi-phase Flow* 3: 201-222
- Davies, C. N. (1973). *Air filtration*. Academic Press, London, New York
- Dral, A. D. G. (1967). The movements of the latero-frontal cilia and the mechanism of particle retention in the mussel (*Mytilus edulis* L.). *Neth. J. Sea Res.* 3: 391-422
- Drew, D. A. (1978). The force on a small sphere in slow viscous flow. *J. Fluid. Mech.* 88: 393-400
- Fenchel, T. (1980a). Suspension feeding in ciliated protozoa:

- structure and function of feeding organelles. Arch. Protistenk. 123: 239–260
- Fenchel, T. (1980b). Relation between particle size selection and clearance in suspension-feeding ciliates. Limnol. Oceanogr. 25: 733–738
- Fenchel, T. (1982a). Ecology of heterotrophic microflagellates. I. Some important forms and their functional morphology. Mar. Ecol. Prog. Ser. 8: 211–223
- Fenchel, T. (1982b). Ecology of heterotrophic microflagellates. II. Bioenergetics and growth. Mar. Ecol. Prog. Ser. 8: 225–231
- Fjerdingstad, E. J. (1961). The ultrastructure of choanocyte collars in *Spongilla lacustris* (L.). Z. Zellforsch. 53: 645–657
- Flood, P. R., Fiala-Medioni, A. (1981). Ultrastructure and histochemistry of the food trapping film in benthic filter-feeders (ascidians). Acta Zool. 62: 53–65
- Foster-Smith, R. L. (1976). Pressures generated by the pumping mechanism of some ciliary filter-feeders. J. exp. mar. Biol. Ecol. 25: 199–206
- Foster-Smith, R. L. (1978). An analyses of water flow in tube-living animals. J. exp. mar. Biol. Ecol. 34: 73–95
- Frost, B. W. (1977). Feeding behavior of *Calanus pacificus* in mixtures of food particles. Limnol. Oceanogr. 22: 472–491
- Gosselin, R. E., O'Hara, C. (1961). An unsuspected source of error in studies of particle transport by lamellibranch gill cilia. J. Cell. comp. Physiol. 58: 1–9
- Gray, J. (1928). Ciliary movement. Cambridge University Press, London
- Gray, J. (1929). The mechanism of ciliary movement. Am. Nat. 63: 68–81
- Happel, J. (1959). Viscous flow relative to arrays of cylinders. Am. Inst. Chem. Eng. J. 5: 174–177
- Ho, B. P., Leal, L. G. (1974). Inertial migration of rigid spheres in two-dimensional unidirectional flows. J. Fluid Mech. 65: 365–400
- Jørgensen, C. B. (1949). Feeding-rates of sponges, lamellibranchs and ascidians. Nature, Lond. 163: 912
- Jørgensen, C. B. (1966). Biology of suspension feeding. Pergamon Press, Oxford
- Jørgensen, C. B. (1975). On gill function in the mussel *Mytilus edulis* L. Ophelia 13: 187–232
- Jørgensen, C. B. (1976). Comparative studies on the function of gills in suspension feeding bivalves, with special reference to effects of serotonin. Biol. Bull. mar. biol. Lab., Woods Hole 151: 331–343
- Jørgensen, C. B. (1981a). A hydromechanical principle for particle retention in *Mytilus edulis* and other ciliary suspension feeders. Mar. Biol. 61: 277–282
- Jørgensen, C. B. (1981b). Feeding and cleaning mechanisms in the suspension feeding bivalve *Mytilus edulis*. Mar. Biol. 65: 159–163
- Jørgensen, C. B. (1982). Fluid mechanics of the mussel gill: the lateral cilia. Mar. Biol. 70: 275–281
- Jordan, T. E., Valiela, I. (1982). A nitrogen budget of the ribbed mussel, *Geukensia demissa*, and its significance in nitrogen flow in a New England salt marsh. Limnol. Oceanogr. 27: 75–90
- Kjørboe, T., Møhlenberg, F., Nøhr, O. (1980). Feeding, particle selection, and carbon absorption in *Mytilus edulis* in different mixtures of algae and resuspended bottom material. Ophelia 19: 193–205
- Kirsch, A. A., Fuchs, N. A. (1967a). The fluid flow in a system of parallel cylinders perpendicular to the flow direction at small Reynolds numbers. J. phys. Soc. Japan 22: 1251–1255
- Kirsch, A. A., Fuchs, N. A. (1967b). Studies on fibrous aerosol filters. II. Pressure drops in systems of parallel cylinders. Ann. Occup. Hyg. 10: 23–30
- Koehl, M. A. R., Strickler, J. R. (1981). Copepod feeding currents: food capture at low Reynolds number. Limnol. Oceanogr. 26: 1062–1073
- Kuenzler, E. J. (1961). Phosphorus budget of a mussel population. Limnol. Oceanogr. 6: 400–415
- Kuwabara, S. (1959). The forces experienced by randomly distributed parallel circular cylinders or spheres in viscous flow at small Reynolds numbers. J. phys. Soc. Japan 14: 527–532
- Leal, L. G. (1980). Particle motions in a viscous fluid. Ann. Rev. Fluid Mech. 12: 435–476
- Lewis, D. B. (1968). Feeding and tube-building in the Fabriciinae (Annelida, Polychaeta). Proc. Linn. Soc. Lond. 179: 37–49
- Miyagi, T. (1958). Viscous flow at low Reynolds numbers past an infinite row of equal circular cylinders. J. phys. Soc. Japan 13: 493–496
- Møhlenberg, F., Riisgård, H. U. (1979). Filtration rate, using a new indirect technique, in thirteen species of suspension-feeding bivalves. Mar. Biol. 54: 143–148
- Moore, H. J. (1971). The structure of the latero-frontal cirri on the gills of certain lamellibranch molluscs and their role in suspension feeding. Mar. Biol. 11: 23–27
- Morton, J. (1967). Guts. Arnold, London
- Nicol, E. A. T. (1931). The feeding mechanism, formation of the tube, and physiology of digestion in *Sabella pavonina*. Trans. R. Soc. Edinb. 56: 537–599
- Nielsen, C., Rostgaard, J. (1976). Structure and function of an entoproct tentacle with a discussion of ciliary feeding types. Ophelia 15: 115–140
- Nival, P., Nival, S. (1976). Particle retention efficiencies of an herbivorous copepod, *Acartia clausi* (adult and copepodite stages): effects of grazing. Limnol. Oceanogr. 21: 24–38
- Orton, J. H. (1912). The mode of feeding of *Crepidula*, with an account of the current-producing mechanism in the mantle cavity, and some remarks on the mode of feeding in Gastropods and Lamellibranchs. J. mar. biol. Ass. U. K. 9: 444–478
- Owen, G. (1974). Studies on the gill of *Mytilus edulis*: the eulaterofrontal cirri. Proc. R. Soc. (Ser. B) 187: 83–91
- Owen, G., McCrae, J. M. (1976). Further studies on the laterofrontal tracts of bivalves. Proc. R. Soc. (Ser. B) 194: 527–544
- Paffenhöfer, G.-A., Strickler, J. R., Alcaraz, M. (1982). Suspension-feeding by herbivorous calanoid copepods: a cinematographic study. Mar. Biol. 67: 193–199
- Randløv, A., Riisgård, H. U. (1979). Efficiency of particle retention and filtration rate in four species of ascidians. Mar. Ecol. Prog. Ser. 1: 55–59
- Reiswig, H. M. (1975). The aquiferous systems of three marine demospongiae. J. Morph. 145: 493–502
- Ribelin, B. W., Collier, A. (1977). Studies on the gill ciliation of the American oyster *Crassostrea virginica* (Gmelin). J. Morph. 151: 439–449
- Rosenberg, G. (1980). Filmed observations of filter feeding in the marine planktonic copepod *Acartia clausii*. Limnol. Oceanogr. 25: 738–742
- Roule, L. (1884). Recherches sur les ascidies simples des cotes de Provence (Phallusiadées). Anns Mus. Hist. nat. Marseille (Zool.) 2(1): 1–270
- Rubenstein, D. I., Koehl, M. A. R. (1977). The mechanisms of filter feeding: some theoretical considerations. Am. Nat. 111: 981–994
- Spielman, L. A. (1977). Particle capture from low-speed laminar flows. Ann. Rev. Fluid. Mech. 9: 297–319

- Spielman, L., Goren, S. L. (1968). Model for predicting pressure drop and filtration efficiency in fibrous media. *Environ. Sci. Technol.* 2: 279-287
- Stokes, G. G. (1851). On the effect of the internal friction of fluids on the motion of pendulums. *Trans. Camb. phil. Soc.* 9: 8-106
- Strathmann, R. R. (1971). The feeding behavior of planktonic echinoderm larvae: mechanisms, regulation and rates of suspension feeding. *J. exp. mar. Biol. Ecol.* 6: 109-160
- Strathmann, R. (1973). Function of lateral cilia in suspension feeding of lophophorates (Brachiopoda, Phoronida, Ectoprocta). *Mar Biol.* 23: 129-136
- Strathmann, R. (1975). Larval feeding in echinoderms. *Am. Zool.* 15: 717-730
- Strathmann, R., Bonar, D. (1976). Ciliary feeding of tornaria larvae of *Ptychodera flava* (Hemichordata: Enteropneusta). *Mar. Biol.* 34: 317-324
- Strathmann, R. R., Leise, E. (1979). On feeding mechanisms and clearance rates of molluscan veligers. *Biol. Bull. mar. biol. Lab., Woods Hole* 157: 524-535
- Strathmann, R. R., Jahn, T. L., Fonseca, J. R. C. (1972). Suspension feeding by marine invertebrate larvae: clearance of particles by ciliated bands of a rotifer, pluteus, and trochophore. *Biol. Bull. mar. biol. Lab., Woods Hole* 142: 505-519
- Tamada, K., Fujikawa, H. (1957). The steady two-dimensional flow of viscous fluid at low Reynolds numbers passing through an infinite row of equal parallel circular cylinders. *Quart. J. Mech. Appl. Math.* 10: 425-432
- Vogel, S. (1981). *Life in moving fluids*. Willard Grant Press, Boston, Mass.
- Wright, R. T., Coffin, R. B., Ersing, C. P., Pearson, D. (1982). Field and laboratory measurements of bivalve filtration of natural marine bacterioplankton. *Limnol. Oceanogr.* 20: 91-98
- Yonge, M. (1935). On some aspects of digestion in ciliary feeding animals. *J. mar. biol. Ass. U. K.* 20: 341-346

This review was submitted to the editor; it was accepted for printing on October 13, 1982