

# Morphological and genetic differentiation of the Black Sea harbour porpoise *Phocoena phocoena*

Karine A. Viaud-Martínez<sup>1,\*</sup>, Milmer Martínez Vergara<sup>1</sup>, Pavel E. Gol'din<sup>2</sup>, Vincent Ridoux<sup>3</sup>, Ayaka A. Öztürk<sup>4</sup>, Bayram Öztürk<sup>4</sup>, Patricia E. Rosel<sup>5</sup>, Alexandros Frantzis<sup>6</sup>, Anastasia Komnenou<sup>7</sup>, Andrew J. Bohonak<sup>1</sup>

<sup>1</sup>Department of Biology, San Diego State University, 5500 Campanile Drive, San Diego, California 92182-4614, USA

<sup>2</sup>Department of Zoology, V. I. Vernadsky Taurida National University, 4 Vernadsky Avenue, Simferopol 95007, Ukraine

<sup>3</sup>Centre de Recherche sur les Mammifères Marins (CRMM), Institut du Littoral et de l'Environnement, Université de La Rochelle, Avenue du Lazaret, 17000 La Rochelle, France

<sup>4</sup>Turkish Marine Research Foundation, P. K. 10, Beykoz, 81650 Istanbul, Turkey

<sup>5</sup>National Marine Fisheries Service, Southeast Fisheries Science Center, 646 Cajundome Blvd, Suite 234, Lafayette, Louisiana 70506, USA

<sup>6</sup>Pelagos Cetacean Research Institute, Terpsichoris 21, 16671 Vouliagmeni, Greece

<sup>7</sup>Veterinary Faculty, Aristotle University of Thessaloniki, St. Voutyra 11, 54627 Thessaloniki, Greece

**ABSTRACT:** The ecological and conservation status of the geographically isolated Black Sea harbour porpoise is currently unknown. Although it has been suggested that Black Sea harbour porpoises are distinct from other populations, the implementation of specific conservation plans has been hindered by the absence of a genetic and morphological study with large sample sizes. We sought to test the hypothesis that Black Sea porpoises differ from those in the Atlantic Ocean using cranial morphology and mitochondrial DNA variation. A total of 177 adult skulls from the Atlantic coast of France, Danish North Sea including Skagerrak and Inner Danish Waters, Greenland and the Black Sea were scored for 22 morphological variables. A portion of the mitochondrial control region was sequenced for 146 ind. from the eastern north Atlantic, the northern Aegean Sea, the Sea of Marmara and the Black Sea. Within the Black Sea, we found relatively low levels of genetic diversity, and no statistically significant differentiation. However, the Black Sea population shares no haplotypes with the eastern Atlantic populations, suggesting that they have been separated for thousands of years. Black Sea porpoises also show significant morphological differences from other populations, with smaller body and skull size, wider and longer rostrum, smaller orbital length, smaller internal nares and condylar widths and larger occipital ridge. Our results demonstrate that harbour porpoises from the Black Sea, Sea of Marmara and the northern Aegean Sea (eastern region): (1) are genetically differentiated; (2) have been reproductively isolated for a considerable period of time; and (3) are likely to be on an independent evolutionary pathway. We recommend that harbour porpoises from the eastern region be recognized as the subspecies *Phocoena phocoena relicta*.

**KEY WORDS:** Conservation genetics · Gene flow · Skull shape · *Phocoena phocoena relicta*

— Resale or republication not permitted without written consent of the publisher —

## INTRODUCTION

Over the past decade, the Black Sea has been the focus of environmental organizations and international protection agencies concerned about increasing pollution, depletion of fish stocks and the associated consequences to its ecosystem. The Black

Sea is a naturally isolated body of water in which 3 cetacean species are found: the common dolphin *Delphinus delphis*, the bottlenose dolphin *Tursiops truncatus*, and the harbour porpoise *Phocoena phocoena*. Although the full extent of human impacts is unknown, it is clear that dolphin fisheries (prior to 1966 in USSR, Romania and Bulgaria, 1983 in Turkey)

and other anthropogenic impacts have dramatically reduced population sizes (e.g. Danilevsky & Tuyutyunnikov 1968, Kleinenberg 1978). Declining water quality and overfishing have also reduced the fish stocks which sustain these cetaceans (e.g. Kideys 1994).

International conservation organizations have recently stressed their concerns for the health of Black Sea harbour porpoises, acknowledging that they have been severely depleted and are seriously threatened (e.g. IWC 2004). Although the Black Sea harbour porpoise has been listed as 'Endangered' by the International Union for Conservation of Nature and Natural Resources (IUCN) (March 2006) and 'Vulnerable' by the Agreement on the Conservation of Cetaceans of the Black Sea, Mediterranean Sea and Contiguous Atlantic Area (ACCOBAMS), protection plans have not been implemented due to a lack of quantitative studies on this population. As a result, the International Whaling Commission (IWC) recommended that further analyses of population genetic structure and life history be conducted to help establish specific conservation plans. Such information would also help resolve the controversial taxonomy surrounding the subspecies denomination of the Black Sea harbour porpoise (IWC 2004, Reeves et al. 2004).

Harbour porpoises are frequently observed in the northeastern Atlantic, but they are absent in the Mediterranean Sea with the exception of the northern Aegean Sea (e.g. Frantzis et al. 2001). They have been reported in the Sea of Marmara and are found throughout the Black Sea-Azov Sea basin (e.g. Öztürk & Öztürk 1996, see Fig. 1).

In a worldwide genetic study that included 9 harbour porpoises from the Black Sea, 3 unique mitochondrial DNA (mtDNA) haplotypes from the Black Sea were found to be more closely related to each other than to Atlantic haplotypes (Rosel et al. 1995). More recently, mtDNA from 2 northern Aegean Sea harbour porpoises was found to be identical to one of the Black Sea haplotypes, suggesting connectivity between these areas (Rosel et al. 2003). However, the degree of genetic differentiation between populations of the Black Sea, the northern Aegean and the Atlantic cannot be determined with accuracy due to low sample sizes. As a result, these studies have had limited conservation impacts.

Morphological studies focused on whether Black Sea harbour porpoises are unique have led to opposite conclusions. For example, Zalkin (1938) found Black Sea harbour porpoises unique enough to be classified as a different subspecies, *Phocoena phocoena relicta* (Abel 1905) while Barabash-Nikiforov (1940) considered this population to be a new species. Kleinenberg (1978) refuted these designations and assigned Black Sea

porpoises to the north Atlantic subspecies *P. phocoena phocoena*, as he did not find significant difference between the Black Sea and Atlantic specimens. Most recently, Gol'din (2004a) supported a subspecies classification for the Black Sea-Sea of Azov harbour porpoise, based on his own body size and skull measurements of Azov porpoises and a review of previous studies. However, no study has had sufficiently large sample sizes from both the Black Sea and other oceans to definitively test the null hypothesis that *P. phocoena relicta* does not differ morphologically from *P. phocoena* elsewhere. Furthermore, past studies have typically pooled specimens of all ages, despite the obvious need to compare body measurements among individuals from the same developmental stage. Most studies have also defined adults as sexually mature individuals, but it is now widely recognized that harbour porpoises are sexually mature prior to attaining physical maturity (e.g. Galatius & Kinze 2003). As a consequence, the degree to which Black Sea harbour porpoises are morphologically distinct from other populations remains unclear.

For the present study, we obtained specimens from the Black Sea, the adjacent Sea of Marmara, the northern Aegean Sea and the eastern Atlantic Ocean. We analyzed variation in skeletal morphology in combination with mitochondrial DNA to: (1) evaluate the degree of morphological and genetic differentiation of the endangered Black Sea harbour porpoise; (2) assess historical demography and divergence time between the Atlantic Ocean and populations to the east; and (3) evaluate the taxonomic status of *P. phocoena* in the Black Sea as it impacts on conservation issues in the region. Our results demonstrate that Black Sea harbour porpoises are morphologically distinct from other populations found elsewhere, and that this population has been genetically isolated for a considerable period of time.

## MATERIALS AND METHODS

Genetic material and morphological measurements were collected in cooperation with representatives from several countries (see 'Acknowledgements').

**Sample collection and sequencing.** Tissue samples were collected between 1997 and 2004 from: (1) the 'eastern region' of the study area, defined as the Black Sea (Ukraine  $n = 58$ , Georgia  $n = 8$ , Bulgaria  $n = 12$  and Turkey  $n = 17$ ), the Sea of Marmara (Turkey  $n = 3$ ) and the northern Aegean Sea (Greece  $n = 4$ ); and (2) the eastern Atlantic (Gibraltar area  $n = 4$ , France  $n = 38$ ) (Fig. 1). To these 144 samples, we added 2 sequences from the northern Aegean Sea and 9 from the Turkish coast of the Black Sea from GenBank (cor-

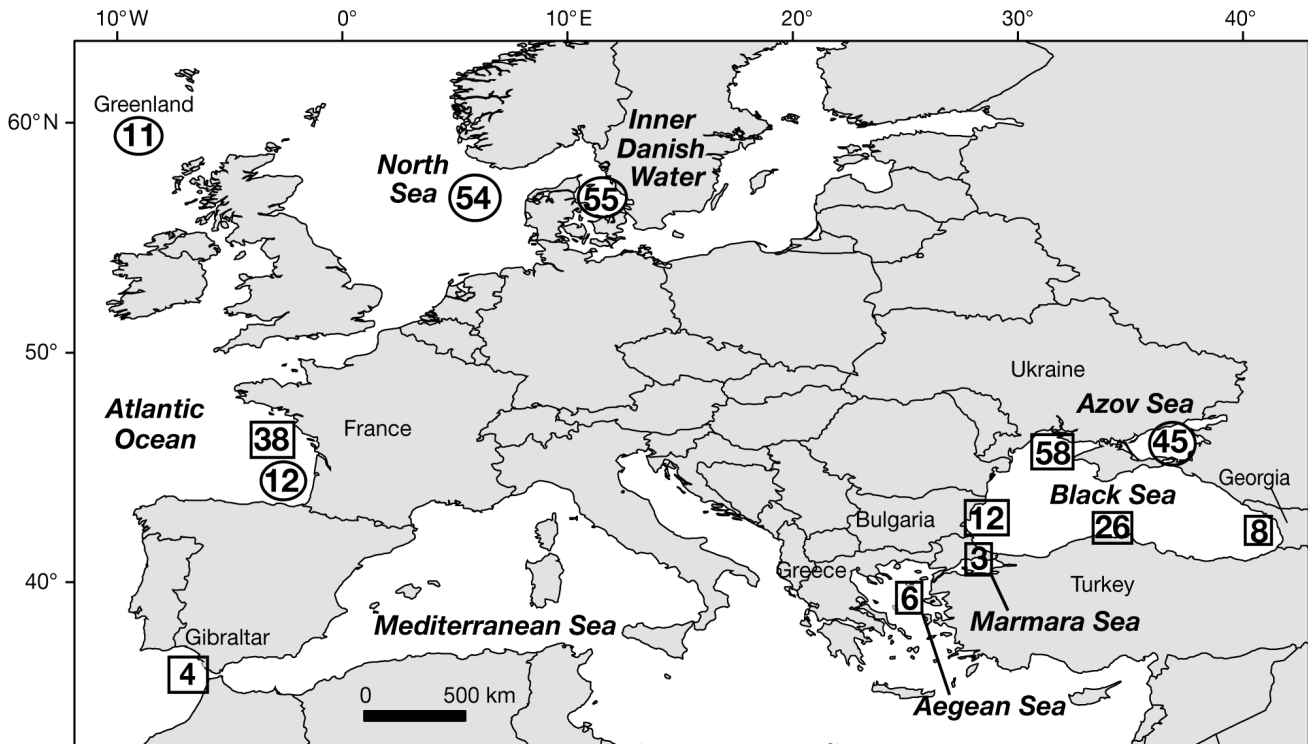

Fig. 1. *Phocoena phocoena*. Sample sizes in the primary study area for the putative populations defined *a priori*. Circled numbers represent the number of skulls measured from each basin. Numbers in squares indicate sample sizes for genetic analyses. Totals for the Aegean Sea and Turkish coast of the Black Sea include sequences from GenBank. See 'Materials and methods'

responding to 3 haplotypes: U09689 = bs1, U09690 = bs2 and U09691 = bs3; Rosel et al. 1995, 2003). Very few of the samples are likely to represent familial groups, since they were obtained by different agencies through a variety of methods (Appendix 1, available in MEPS Supplementary Material at [www.int-res.com/articles/suppl/m338p281\\_app.pdf](http://www.int-res.com/articles/suppl/m338p281_app.pdf)). Tissue was preserved in 20% dimethyl sulphoxide saturated with sodium chloride (DMSO) at  $-20^{\circ}\text{C}$ . Aegean samples were extracted using proteinase K digestion followed by standard phenol-chloroform extraction, while DNA for all other samples was extracted using DNEasy kits (Qiagen). The first 364 base pairs of the mitochondrial DNA (mtDNA) control region were amplified and sequenced in both directions using primers L15824 and H16265 (Rosel et al. 1999). Ten ng of genomic DNA were added to a 25  $\mu\text{l}$  reaction mixture containing 2.5  $\mu\text{l}$  of  $10\times$  Taq buffer (20 mM  $\text{MgCl}_2$ ), 1  $\mu\text{l}$  of each primer at 10  $\mu\text{M}$ , 2.5  $\mu\text{l}$  of 8 mM deoxyribonucleotide triphosphate (dNTPs) and 0.25  $\mu\text{l}$  of Taq DNA polymerase (New England Biolabs). The PCR thermal profile was 2 min at  $94^{\circ}\text{C}$ , 35 cycles of {45 s at  $94^{\circ}\text{C}$ , 1 min at  $51^{\circ}\text{C}$ , 1.5 min at  $72^{\circ}\text{C}$ }, and 5 min at  $72^{\circ}\text{C}$ . PCR products were purified using QIAquick Spin kits (Qiagen), cycle sequenced using BigDye v.3.1 (ABI), and run on an ABI 3100 sequencer. We aligned sequences by eye

using Sequencher v.3.1 (Gene Codes Corp.). Aegean samples were amplified using the same primers following the protocol in Rosel et al. (1999). Sequences were submitted to GenBank (accession numbers from EF063646 to EF063675 and EF063110).

**Population genetic analysis.** Pairwise distances were calculated with PAUP\* (Swofford 1998) using a Hasegawa-Kishino-Yano with invariable sites (HKY+I) model of sequence evolution, which was the best model estimated from a likelihood ratio test in the program MODELTEST (Posada & Crandall 1998) (Akaike information criterion were frequency (A) = 0.3271, frequency (C) = 0.2377, frequency (G) = 0.0999, frequency (T) = 0.3353; transition/transversion [Ti/Tv] ratio = 34.329; proportion of invariable sites  $I = 0.7196$ ). Using Arlequin v.3.01 (Schneider et al. 2001) genetic diversity was summarized as proportion of polymorphic sites ( $S$ ), haplotype diversity ( $H_e$ ) (equivalent to expected heterozygosity, adjusted for population size), and nucleotide diversity ( $\pi$ ; Nei 1987). The null hypothesis of no genetic divergence was tested using contingency tables (Arlequin v.3.01). We ran hierarchical analysis of molecular variance (AMOVA) and tested for differences among the 8 localities, among the 4 Black Sea populations, and between the eastern region (113 samples from Ukraine, Bulgaria, Georgia and

Turkey in the Black Sea, the Sea of Marmara and northern Aegean Sea) and the Atlantic (42 samples from France and Gibraltar area). AMOVA was used to quantify the degree of subdivision in both cases as conventional  $F_{ST}$  and  $\theta_{ST}$  (Excoffier et al. 1992), with the distance matrix created in PAUP\*.

**Phylogenetic analyses of haplotypes.** We estimated the evolutionary relationships among haplotypes using network parsimony reconstruction in TCS v.1.13 (Clement et al. 2000). Network parsimony methods perform better than traditional phylogenetic methods when few mutational steps separate recently diverged alleles, and ancestral nodes are not yet extinct (reviewed by Posada & Crandall 2001). Geographic associations were assessed for each clade using Geodis 2.5 (Posada et al. 2000). This approach calculates several geographic association metrics for each clade based on individual sampling locations, and the null hypothesis of no geographic association was tested with 100 000 permutations in each case. For clades with statistical significance, evolutionary processes were inferred using the most recent version (2005) of the GeoDis inference key, which suggests likely scenarios regarding gene flow and/or population history. This entire approach, known as nested clade phylogenetic analysis (NCPA) is defended by Templeton (2004) in response to criticisms regarding the final inference key (Knowles & Maddison 2002). In light of this debate, we consider the NCPA inferences to be working hypotheses, interpretable in the context of other frequency- and coalescent-based analyses. For clades where patterns of isolation by distance (IBD) were suggested, IBD was visualized by plotting genetic similarity ( $\log$  of  $F_{ST}$ , from Arlequin output) as a function of  $\log$  (geographic distance) for each population pair. Because Black Sea samples were collected in coastal waters of each of the 4 countries, geographic distances (km) were calculated as straight lines between coastline mid-points for each country. Mantel tests of the IBD relationship were performed using the program IBDWS (Jensen et al. 2005).

**Estimation of gene flow, effective population sizes and coalescent time.** Because our analyses suggested long-standing isolation between the Atlantic Ocean and eastern region (Black Sea, Sea of Marmara and northern Aegean Sea), we estimated historical and contemporary connectivity between the Atlantic and eastern region using the 'isolation with migration' (IM) model of Hey & Nielsen (2004). The IM software simulates the coalescent process to estimate the following parameters: (1) the standard population genetic parameter  $\theta_A$  for an ancestral population ( $\theta = 4N_e\mu$ ,  $N_e$  = effective population size,  $\mu$  = mutation rate per generation per gene); (2) the parameter  $\theta$  for 2 populations that have evolved from the ancestral population (in our

analyses,  $\theta_1$ : eastern region;  $\theta_2$ : Atlantic); (3)  $s$  = the fraction of the ancestral population that founded the eastern region; (4) migration rates between populations,  $m_1$  (from the Atlantic to the eastern region) and  $m_2$  (vice versa), scaled by mutation rate (these parameters can be converted to the average number of migrants per generation  $M_1$  and  $M_2$ ); (5) the time  $t$  since the populations diverged, scaled by mutation rate. Convergence of the model was assessed by monitoring multiple independent runs, and by examining parameter autocorrelations during each run. All models were run with >2 000 000 cycles (burn-in = 200 000), inheritance scalar = 0.25, and HKY mutation model (Palsbøll et al. 2004) with assigned upper and lower range of the population splitting parameter ( $s$ ) of 0.1 and 0.5. The range of known mutation rates for marine mammals (0.5 to 7% per million years, Hoelzel et al. 1991, Harlin et al. 2003) and a generation time of 6 yr (Chivers & Taylor 1997) were used to calculate effective population sizes and divergence time.

**Morphological measurements.** We analyzed 177 adult harbour porpoises for body size and 22 cranial measurements (Appendices 2 & 3 available in MEPS Supplementary Material at [www.int-res.com/articles/suppl/m338p281\\_app.pdf](http://www.int-res.com/articles/suppl/m338p281_app.pdf)). These specimens (which differed from those used for genetic analysis) came from the Black Sea-Azov basin (24 females, 21 males), France (7 females, 5 males), Greenland (4 females, 7 males), Danish North Sea including Skagerrak (28 females, 26 males) and Inner Danish Waters (IDW; 27 females, 28 males). We analyzed Greenland, the North Sea, France and IDW as distinct populations. We treated the Black Sea-Azov Sea basin as a single population, and refer to it simply as the Black Sea.

Measurements were taken on the right side of each skull to avoid redundancy and bias due to skull asymmetry (e.g. Arvy 1977). Criteria such as complete vertebral epiphyseal ankylosis and distal fusion of the maxillae and premaxillae used to determine physical maturity in Delphinidae (Perrin & Heyning 1993) cannot be applied to harbour porpoises, since a consistent degree of physical maturity is rarely observed even in old specimens (Galatius & Kinze 2003). In harbour porpoises, sexual maturity can be attained years before body parts such as the flipper reach complete ankylosis (Galatius & Kinze 2003, Galatius et al. 2006); consequently, sexual maturity is an inadequate approximation of physical maturity. We assumed that an individual was fully grown when the flippers had reached physical maturity as defined by the complete epiphyseal ankylosis of the humerus, radius and ulna. The flipper was considered mature when epiphyses were fused to the bone with clear suture (stage D as defined by Galatius & Kinze 2003). Flipper maturity

seemed to best approximate skull maturity because recent studies have demonstrated that skull and flippers are both characterized by negative allometry and show low correlation with total body size (e.g. Galatius 2005). Moreover, the developmental timing of the humerus, radius and ulna is similar for males and females and shows less individual variation than the vertebral column (e.g. Galatius & Kinze 2003). Also, epiphyses of the humerus, radius and ulna have consistent developmental timing across individuals (Galatius et al. 2006). Our criteria facilitated a conservative selection of specimens, since those that we chose had all attained at least 95% of the asymptotic length. For example, 95% of asymptotic length is reached in females and males of 4.9 and 3.9 yr old in the IDW (Galatius 2005), and approximately 3 yr old for both sexes in the Black Sea (Gol'din 2004b). The females and males we selected averaged 9.7 and 7.9 yr old respectively in the Atlantic, and 8.2 and 7.5 yr old respectively in the Black Sea (age information available from museum archives and other studies, e.g. Gol'din 2004b, Galatius et al. 2006).

Because sexual dimorphism in this species is well known (females are larger than males and have different skeletal proportions, e.g. Galatius 2005), we performed separate statistical analyses for males and females. Missing measurements (3.8% of the total data set) were estimated using the expectation maximization method (e.g. Strauss et al. 2003).

For each sex, a multivariate analysis of variance (MANOVA) was used to test for morphological divergence among localities using direct measurements. Significant results were interpreted with post hoc tests. In separate analyses, we tested for differences between: (1) the Black Sea and all individuals from the Atlantic; and (2) all 5 populations for which skull measurements were taken (Black Sea, France, Greenland, North Sea and IDW).

For each sex, we performed a principal component analysis (PCA) on the direct measurements using the correlation matrix, which standardizes the variables (no factor rotation, extraction parameter: minimum eigenvalue = 1). Individuals from Greenland were excluded due to low sample sizes (4 females, 7 males). Analysis of variance (ANOVA) was used to test whether each principal component differed among 4 populations (Black Sea, France, North Sea and IDW). We also used discriminant function analyses (DFA) based on direct measurements to identify the variables that best discriminate these populations. Because DFA adjusts for covariance within groups, the analysis was performed on the covariance matrix of the input data. We used a tolerance limit for the matrix inversion of 0.001 and forward stepwise variable selection (probability of 0.2 and 0.08 for variable extraction

for males and females respectively). To find the optimum number of principal components and variables that robustly discriminate populations, additional exploratory PCA and DFA analysis were performed using different types of factors rotation and extraction parameters. Shape differences observed with the PCA and DFA were tested with a MANOVA after standardizing each measurement as the percentage of total skull length ( $[\text{direct measurement}/\text{condylobasal length}] \times 100$ ).

## RESULTS

### Population genetic structure

Thirty-two unique mitochondrial haplotypes were found in 155 ind., and 6 of these were shared among populations (Fig. 2). Thirty of 364 base pair positions were polymorphic, with one insertion/deletion and 29 substitutions. Only 19 haplotypes were found in 113 ind. from the eastern region, with the most common haplotype represented by 76 ind. There were no shared haplotypes between the Atlantic and eastern region (Fig. 2). Individuals from the Atlantic Ocean near Gibraltar possessed 2 unique haplotypes. One of the 2 haplotypes found in the 6 Aegean samples was shared with the Black Sea and the other was unique. Unexpectedly, all 3 ind. from the Sea of Marmara (located between the Aegean Sea and Black Sea) possessed a unique haplotype.

Haplotype diversity and nucleotide diversity were lower in the eastern region ( $H_e = 0.542$ ,  $\pi = 0.0019$ ) than in the Atlantic population ( $H_e = 0.800$ ,  $\pi = 0.0085$ ) or other populations from previous studies (e.g.  $H_e = 0.779$ ,  $\pi = 0.0081$  for Iceland, and  $H_e = 0.967$ ,  $\pi = 0.0108$  for the Gulf of St. Lawrence: Tolley et al. 2001). Genetic diversity was low in all 6 populations in the eastern region (Table 1).

Differentiation among the 8 localities was highly significant overall (AMOVA:  $\theta_{ST} = 0.635$ ,  $F_{ST} = 0.276$ ,  $df = 154$ , overall  $p < 0.001$ ). Exact tests of haplotype distributions supported significant differences between localities ( $p < 0.001$ ). However, population differentiation was not statistically significant within the Black Sea (AMOVA:  $\theta_{ST} < -0.001$ ,  $F_{ST} = -0.014$ ,  $df = 103$ , exact test  $p = 0.519$ ), or between the Aegean Sea and putative populations in the Black Sea (all pairwise exact test  $p > 0.4$ , Table 2). The Sea of Marmara differed from all other localities despite its small sample size (Table 2). Differentiation between the eastern region and the Atlantic was highly significant when tested by AMOVA ( $\theta_{ST} = 0.730$ ,  $F_{ST} = 0.312$ ,  $p < 0.001$ ,  $df = 154$ ) and an exact test of haplotype distributions ( $p < 0.001$ ).

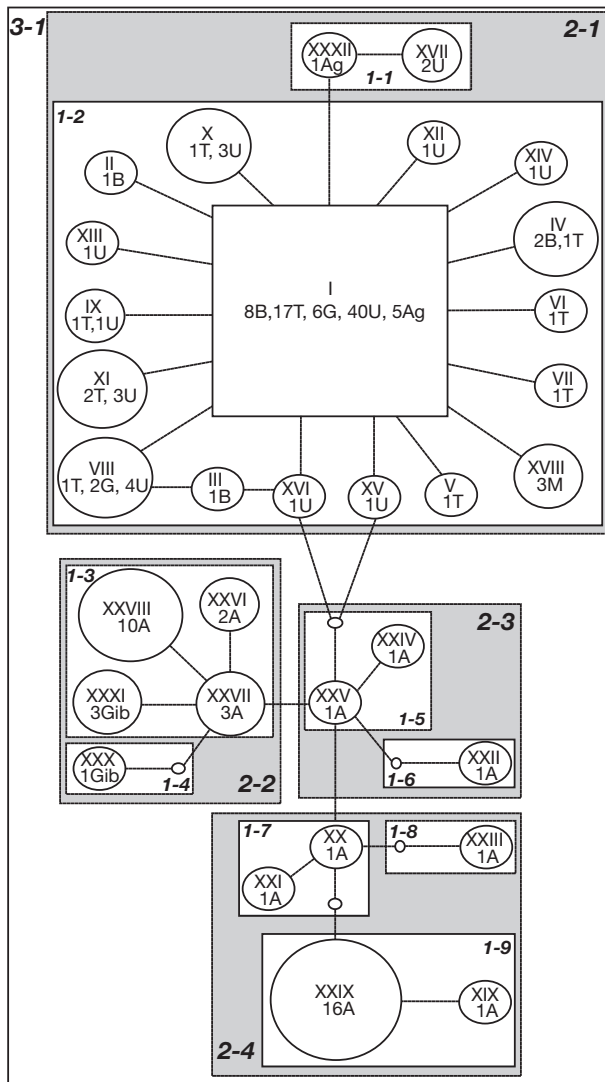

Fig. 2. *Phocoena phocoena*. Haplotype network for mitochondrial DNA. Population codes are: Black Sea [(U) Ukraine, (B) Bulgaria, (T) Turkey, (G) Georgia]; (M) Sea of Marmara; (Ag) northern Aegean Sea; (Gib) Gibraltar Area; (A) Atlantic coast of France. Oval size is proportional to the number of individuals, which precedes the population code. Each line represents one mutational step, and empty ovals are unsampled haplotypes. Three levels of nesting are enclosed in successively larger boxes

### Population history and population parameter estimates

The mtDNA haplotype network verified moderate to high levels of divergence among localities, with no haplotypes shared between the Atlantic and eastern region (Fig. 2) (Network topology was completely congruent with a rooted tree generated using standard unweighted parsimony). The Atlantic portion of the genealogy was complex, with a maximum diver-

gence of 7 mutational steps between haplotypes. In contrast, the vast majority of eastern haplotypes are only one mutational step away from the common ancestral allele I. Such 'star' phylogenies are expected under restricted patterns of gene flow (Templeton 1998). The data suggest that the Atlantic and eastern region have been isolated for a long enough period of time to share no haplotypes, despite large sample sizes ( $n = 155$  total ind.). Depending on where the network is rooted the eastern region may represent a monophyletic group.

Based on the NCPA, 3 clades (1-2; 1-3; 3-1) possessed significantly non-random geographic associations (Fig. 2). The inference key suggested limited gene flow with isolation by distance for clade 1-2 (among populations within the Black Sea). The specific inference for clade 1-3 (France and Gibraltar) remained unresolved due to our inability to sample populations between France and Gibraltar for this study (additional samples from Portugal and Mauritania would be needed to directly assess whether individuals from Gibraltar are part of an African population). For the entire data set (clade 3-1), the inference key suggested a colonization event followed by population fragmentation. This is consistent with complete or near-complete genetic isolation between the Atlantic and eastern region, and with the historical absence of *Phocoena phocoena* from the Mediterranean Sea except the northern Aegean Sea (Frantzis et al. 2001).

We further tested the NCPA inference of isolation by distance among the Black Sea populations using the IBDWS program (Fig. 3). Genetic similarity declines with geographic distance in the Black Sea (Mantel Test;  $p = 0.040$ ) even though population structure within the Black Sea was not statistically significant (see above). We concluded that the stepping stone migration model, which provides the basis for the IBD analysis, is more sensitive than an island model (which is the implicit basis of AMOVA).

Fig. 4 shows the posterior distributions for the 7 parameters in the IM model of divergence between the Atlantic and the eastern region. Posterior distributions from multiple independent long runs were identical and parameter autocorrelations decreased rapidly at the beginning of each run. Probability distributions of  $\theta_1$  and  $\theta_2$  had clear maxima with maximum likelihood (ML) estimates of  $\theta_1 = 16.9$  (95Lo–95Hi: 11.0–33.6) for the eastern region, and  $\theta_2 = 17.5$  (10.0–39.4) for the Atlantic. Probability distributions of  $\theta_A$  had a maximum near zero with the ML estimate of  $\theta_A = 0.26$  (0.2–27.1) for the ancestral population. The parameter  $\theta$  can be translated to effective population size  $N_e$  if the per generation mutation rate  $\mu$  is known. Assuming a mutation rate of  $\mu = 0.5\%$  per site per million years (Hoelzel et al. 1991) and a gen-

Table 1. *Phocoena phocoena*. Genetic diversity for mitochondrial DNA. Haplotype diversity is equivalent to expected heterozygosity, corrected for population size (Nei 1987); error  $\pm$ SD

Population	No. of mtDNA samples	No. of haplotypes	No. of polymorphic sites	Haplotype diversity	Nucleotide diversity
Bulgaria	12	4	4	0.561 $\pm$ 0.154	0.0022 $\pm$ 0.002
Turkey	26	9	8	0.578 $\pm$ 0.111	0.0019 $\pm$ 0.002
Georgia	8	2	1	0.429 $\pm$ 0.168	0.0012 $\pm$ 0.001
Ukraine	58	11	11	0.520 $\pm$ 0.079	0.0018 $\pm$ 0.001
Marmara	3	1	0	0	0
Aegean	6	2	1	0.333 $\pm$ 0.215	0.0009 $\pm$ 0.001
Gibraltar	4	2	3	0.500 $\pm$ 0.265	0.0041 $\pm$ 0.003
France	38	11	13	0.759 $\pm$ 0.054	0.0081 $\pm$ 0.005
Total	155	32	30		

Table 2. *Phocoena phocoena*. Genetic differentiation estimated with  $\theta_{ST}$  (above the diagonal) and  $F_{ST}$  (below the diagonal). \* $p < 0.05$  for  $\theta_{ST} > 0$  and for the pairwise exact test

Locality	Bulgaria	Turkey	Georgia	Ukraine	Marmara	Aegean	Gibraltar	France
Bulgaria		0.003	0.002	0.019	0.571*	-0.008	0.821*	0.605*
Turkey	-0.021		0.013	-0.010	0.586*	-0.033	0.862*	0.663*
Georgia	0.005	-0.019		-0.006	0.748*	0.080	0.862*	0.604*
Ukraine	0.002	-0.017	-0.028		0.581*	-0.047	0.871*	0.716*
Marmara	0.576*	0.537*	0.688*	0.566*		0.803*	0.862*	0.617*
Aegean	-0.026	-0.0335	-0.021	-0.032	0.566*		0.860*	0.590*
Gibraltar	0.459*	0.442*	0.546*	0.484*	0.707*	0.599*		0.337*
France	0.319*	0.324*	0.355*	0.370*	0.409*	0.374*	0.315*	

eration time estimate of 6 yr (Chivers & Taylor 1997), the effective size for the ancestral population is estimated to be  $N_A = 5952$  ind. (95Lo–95Hi: 4579–620 421 ind.). The distribution of the splitting parameter ( $s$ ) gives a maximum likelihood estimate of  $s = 0.05\%$  (95Lo–95Hi: 0.05%–44.05%), suggesting that 0.05% of the ancestral population (approx. 3 ind. for  $N_A = 5952$ ) would have left the ancestral gene pool to found the eastern population. The qualitative conclusion that a dramatic bottleneck was associated with the founding of the eastern region (Black Sea, Sea of Marmara and northern Aegean Sea) seems biologically reasonable, although we acknowledge limitations of the IM model and an absence of data from (now extinct) populations in the Mediterranean Sea. Maximum likelihood estimates for recent effective population sizes are considerably larger, with  $N_1 = 386\,905$  ind. estimated for the eastern region (95Lo–95Hi: 251 832–769 231 ind.) and  $N_2 = 400\,641$  ind. for the Atlantic (228 938–902 015 ind.). Our population size estimates might be high since we used the conservative mutation rate of 0.5% per million years. If this is increased to 7% per million years (Harlin et al. 2003), the maximum likelihood estimate for effective population size decreases to  $N_A = 425$  ind. for the ancestral population (95Lo–95Hi: 327–44 315

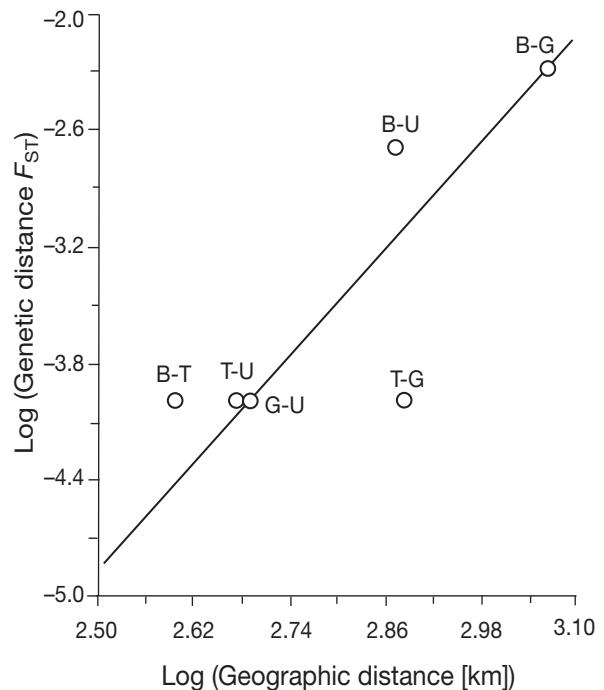

Fig. 3. *Phocoena phocoena*. Isolation by distance plot for all pairs of Black Sea populations: (B) Bulgaria; (T) Turkey; (U) Ukraine; (G) Georgia. The association is statistically significant (Mantel test;  $p = 0.040$ )

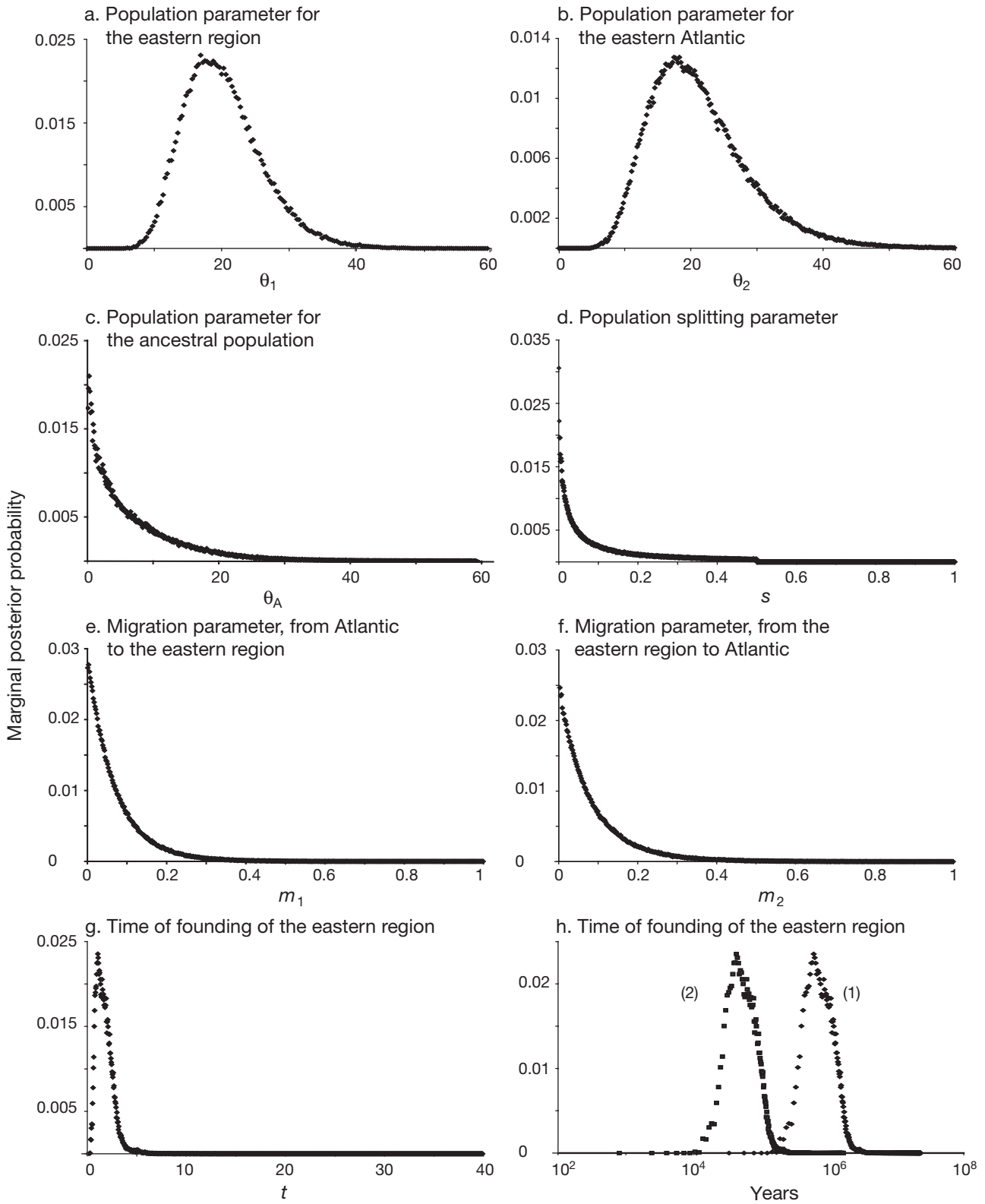

Fig. 4. *Phocoena phocoena*. Marginal posterior probability distributions for model parameters, scaled by the neutral mutation rate. (a, b, c) Population parameters for: ( $\theta_1$ ) the eastern region; ( $\theta_2$ ) the Atlantic; and ( $\theta_A$ ) the ancestral population. (d) Population splitting parameter (s). (e, f) Migration rates between the eastern region and the Atlantic ( $m_1$ ,  $m_2$ ). (g, h) Time parameter (t) and time in years since population divergence began. For (h) the scale is in years assuming mutation rate of (1) 0.5% and (2) 7% per million years



ind.);  $N_1 = 27\,636$  ind. for the eastern populations (95Lo–95Hi: 17 988–55 010 ind.) and  $N_2 = 28\,617$  ind. for the Atlantic (16 353–644 297 ind.). Overall, these results quantify the inference of recent population growth that one would associate with the recent burst of rare new alleles from haplotype I.

Both migration parameters ( $m_1, m_2$ ) had the highest probabilities for the zero interval, supporting the NCPA conclusion that the 2 localities have had near-zero levels of gene flow since they began to diverge. With  $\mu = 0.5\%$  per site per million years, the maximum likelihood estimate of  $t = 1.06$  corresponds to a divergence time of 582 418 yr BP between the eastern Atlantic and the eastern region. Using a 95% posterior density interval (95Lo–95Hi: 0.58–3.66), we estimate a confidence interval for the time of divergence as (318 681–2 010 989) yr BP. Our estimate of 582 418 yr is a conservative upper range of time divergence. The highest mtDNA mutation rate observed for marine mammals is 7% per million years (Harlin et al. 2003); which reduces the maximum likelihood estimate of divergence time to 41 601 yr (95Lo–95Hi: 22 763–143 642) (Fig. 4h). We note that the large ranges for these estimates reflect stochasticity in the evolutionary process, but do not include additional unknown levels of error in our assumptions about mutation rate and generation time.

### Morphology

Female and male harbour porpoises differed significantly among the Black Sea, northeastern Atlantic, Greenland, North Sea and IDW in terms of total body length (ANOVA,  $p < 0.001$ ,  $df = 79$  for males;  $p < 0.001$ ,  $df = 86$  for females) and 22 skull measurements (for each sex, MANOVA,  $p < 0.001$ ,  $df = 92$ ). Male and female specimens were significantly smaller in the Black Sea than other populations for most measurements (Table 3). For example, mean body lengths were 132.4 cm and 144.5 cm for Black Sea males and females, compared to 164.4 cm and 173.0 cm for France. Similarly, mean skull lengths in the Black Sea

Table 3. *Phocoena phocoena*. Summary of ANOVA Scheffé  $F$ -test as the post hoc tests between the Black Sea and Atlantic Ocean for 22 morphological variables: (CBLN) condylobasal length; (ROST) length of rostrum; (TIPN) tip of rostrum to external nares; (ROSW) rostrum width at base; (PREO) preorbital width; (POST) postorbital width; (ZYGO) zygomatic width; (PARI) parietal width; (BRNH) braincase height; (BRNL) braincase length; (FCCC) frontal crest to occipital condyle base; (CONM) maximum width of occipital condyles; (ORBI) length of orbit; (ANTO) length of antorbital process; (INTN) width of internal nares; (PMXB) width of premaxillaries at base; (EXTN) width of external nares; (PMXM) maximum width across premaxillaries; (NASM) maximum width of nasals; (RAML) maximum length of ramus; (RAMH) maximum height of ramus; (OCRL) maximum length of occipital ridge. Statistical significance ( $p < 0.05$ ) is specified for: (d) direct measurements; (p) proportions; and (DFA) variables that best-discriminate the Black Sea. (ns) no significant differences; (na) data not available

Variables	Population mean % of skull length					
	Males			Females		
	Atlantic (n = 66)	Black Sea (n = 21)	Statistical significance	Atlantic (n = 66)	Black Sea (n = 24)	Statistical significance
<b>Skull length</b>						
CBLN	na	na	d, DFA	na	na	d
<b>Rostrum</b>						
ROST	44.1	45.1	d, p, DFA	44.7	45.8	d, p
TIPN	56.4	58.1	d, p, DFA	57.3	59.4	p
ROSW	27.0	29.3	p, DFA	28.0	29.5	p
<b>Skull width</b>						
PREO	45.5	48.7	p, DFA	46.3	48.9	p, DFA
POST	56.9	58.4	d, p, DFA	57.6	58.4	d
ZYGO	59.4	61.2	d, p	60.1	60.7	d
PARI	49.7	51.1	d, p	48.2	48.3	d
<b>Braincase</b>						
BRNH	32.3	32.6	d	31.1	30.6	d
BRNL	39.6	39.9	d	38.9	38.2	d, p
FCCC	48.1	48.7	d, DFA	47.2	47.6	d
<b>Others</b>						
CONM	25.4	24.4	d, p	25.6	24.2	d, p, DFA
ORBI	18.3	17.8	d, p	18.4	17.2	d, p, DFA
ANTO	9.4	9.6	ns	9.4	9.4	d, DFA
INTN	17.5	16.8	d, p, DFA	18.1	17.1	d, p
PMXB	12.1	12.0	d, DFA	12.6	12.3	d
EXTN	11.1	11.5	d, p	11.1	11.6	p
PMXM	14.9	14.7	d	15.1	15.2	d
NASM	12.8	12.7	d	12.9	12.3	d
RAML	77.8	77.8	d	78.1	78.6	d
RAMH	20.9	21.3	d, p	21.5	21.4	d
OCRL	1.3	1.7	p, DFA	1.9	2.7	d, p, DFA

were 239.2 mm and 254.5 mm for males and females respectively (maxima of 249 mm and 266 mm), compared to mean lengths of 273.6 mm and 285.7 mm for France. Specimens from Greenland, North Sea and IDW were of intermediate sizes (Table 4).

For females, principal components PC1 and PC2 explained 53.7% and 9.5% of the total variance respectively, and significantly differentiated Black Sea porpoises from those of other oceans. PC1 differentiated the Black Sea porpoises from those in the Atlantic and PC2 discriminated the Black Sea from the North Sea and IDW (MANOVA,  $p < 0.001$  for all,  $df = 6$ , Fig. 5a). Correlations between skull measurements and PC1 were large and positive (loadings  $> 0.30$ ), and can

Table 4. *Phocoena phocoena*. Total body length and skull length (condylobasal length) for harbour porpoises from 5 localities; average measurement (minimum value; maximum value); n = number of specimens measured

	Total body length (cm)		Skull length (mm)	
	Female	Male	Female	Male
France	173.0 (153; 190) n=7	164.4 (150; 176) n=5	285.7 (257; 313) n=6	273.6 (265; 287) n=5
IDW	159.0 (140; 175) n=27	144.4 (132; 155) n=28	270.2 (253; 291) n=26	258.3 (247; 285) n=27
North Sea	150.9 (138; 170) n=28	140.7 (133; 154) n=25	264.5 (248; 281) n=27	252.9 (241; 263) n=24
Greenland	153.4 (151.5; 154) n=4	139.1 (133; 145) n=7	265.7 (264; 268) n=3	244.5 (231; 253) n=6
Black Sea	144.5 (130; 160) n=21	132.4 (115; 140) n=15	254.5 (244; 266) n=24	239.2 (228; 249) n=20

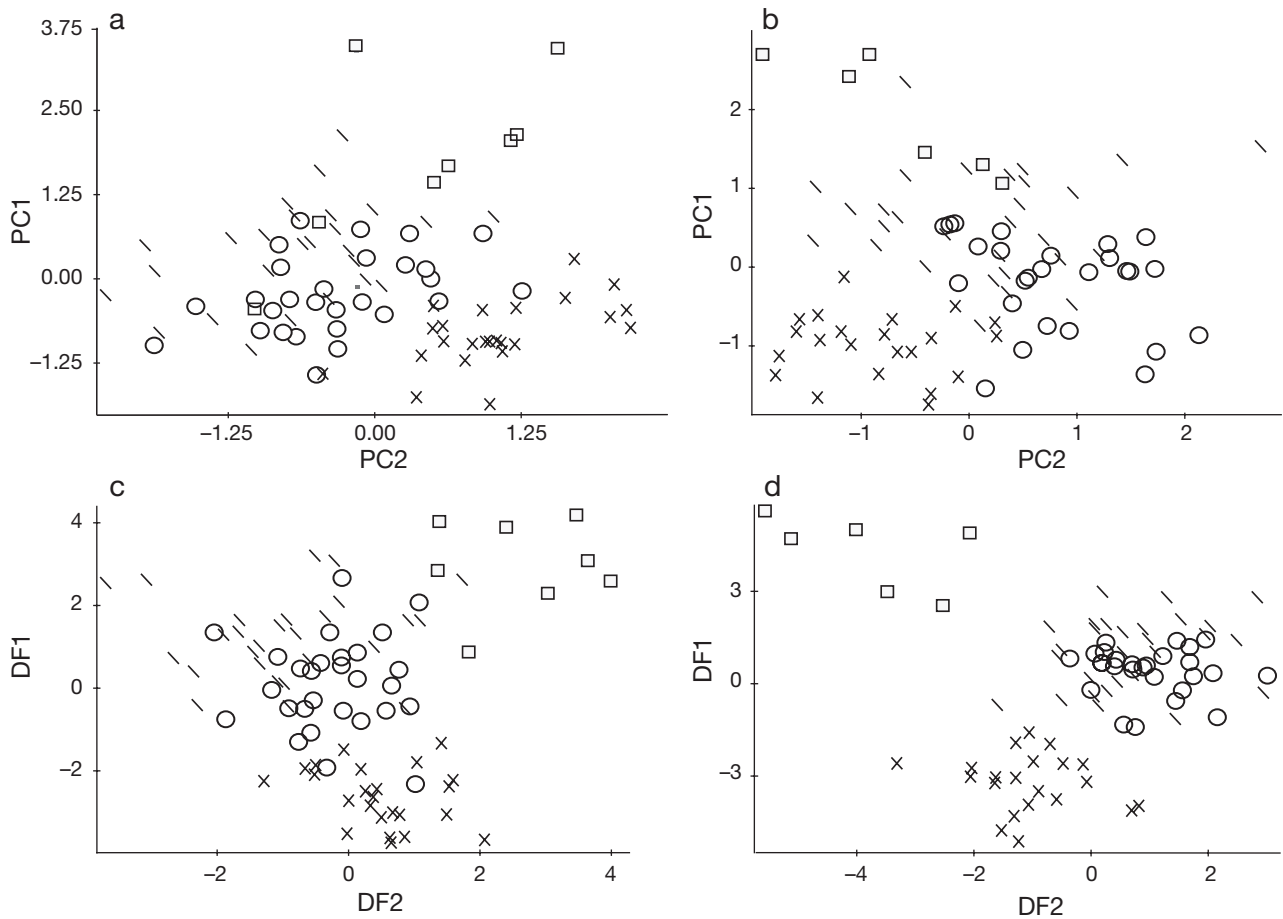

Fig. 5. *Phocoena phocoena*. Results from multivariate morphological analyses. Principal components PC1 and PC2 for (a) females and (b) males. Canonical factors DF1 and DF2 for (c) females and (d) males. Each point represents an individual from: (x) Black Sea; (v) Inner Danish Waters; (O) North Sea; (□) Atlantic coast of France

be interpreted as a multivariate measure of overall skull size, with high values representing larger skulls. PC2 loaded positively and highly on variables characterizing rostrum length and width, and the length of the occipital ridge (loadings >0.36), but negatively on brain size measurements (parietal width, brain height and length), length of orbit, internal nares and condylar widths (loadings <-0.3). Thus, individuals with high values for PC2 have proportionally longer and wider rostra, larger occipital ridge, smaller orbital length, and

smaller internal nares and condylar widths. Because Black Sea female porpoises displayed low PC1 values (mean = -0.81) and high PC2 values (mean = 1.05), they have a relatively small skull with proportionally longer and wider rostrum, large occipital ridge, small orbital length, and small internal nares and condylar widths.

For males, PC1 and PC2 significantly differentiated specimens from the 4 localities, explaining 51.9 and 9.5% of the total variance (MANOVA,  $p < 0.001$ ,  $df = 6$ , Fig. 5b). As with females, PC1 represents a multivariate

measure of overall skull size. PC2 loaded positively on skull length measurements (e.g. condylobasal length) as well as orbital length and condylar width (loadings >0.3), but also loaded heavily and negatively on skull width measurements (pre-orbital, post-orbital, zygomatic, rostrum widths relative to skull size, loadings <-0.3). Individuals with high PC2 values are characterized by a longer but proportionally narrower skull with greater orbital length and condylar width. Because Black Sea male porpoises displayed low PC1 values (mean = -0.96) and low PC2 values (mean = -0.85), they are characterized by a smaller but proportionally wider skull with smaller orbital length and condylar width.

Discriminant function analysis (DFA) of skull morphology discriminated the Black Sea, France, North Sea, and IDW populations (Fig. 5c,d). Only 5 of 22 variables are needed for female discrimination (Table 3), with 100% classification success for the Black Sea and an overall 75% classification success. Canonical factors DF1 and DF2 explained 3.4% and 1.1% of the total variance and can be interpreted in terms of skull shape (Fig. 5c). DF1 loaded positively on orbital length and condylar width (0.277 and 0.204 respectively) and negatively on the length of the occipital ridge (-0.237). DF2 loaded positively on the antorbital process width (0.310) and discriminated females from France from those of other populations. Because Black Sea females displayed low DF1 (mean = -2.6) and DF2 values near zero, they are characterized by small condylar width and orbital length, and large occipital ridge. Females from France with highest DF2 values have proportionally larger antorbital processes, compared to Black Sea, North Sea and IDW females.

Males can be discriminated using 10 out of 22 variables with 100% classification success for the Black Sea and France, and an overall 81% classification success (Table 3). North Sea and IDW specimens could not be differentiated with this analysis. Canonical factors DF1 and DF2 explained 4.8 and 1.1% of the total variance (Fig. 5d). DF1 discriminated the Black Sea from Atlantic populations, while DF2 discriminated the Black Sea from France and France from North Sea and IDW. DF1 loaded positively on several length and width measurements (loadings >0.2) and negatively on rostrum width (-0.101) and tip of rostrum to external nares (-0.244). DF2 loaded negatively on rostrum length (-0.338) and the length of the occipital ridge (-0.370), and positively on internal nares width (0.230). Because male Black Sea porpoises display low value of DF1 (mean = -3.2) and DF2 (mean = -1.1), they are characterized by a wider and longer rostrum relative to skull size with smaller internal nares and larger occipital ridge compared to other populations.

Results of the principal component analysis and the discriminant function analysis on direct measurements

were found to be statistically significant using the MANOVA on measurement percentage of total skull length (Table 3). Black Sea porpoises can thus be differentiated from those of the Atlantic Ocean with the following criteria (Table 3, Fig. 5): (1) Black Sea males and females are the smallest specimens; (2) proportionally, the back of the skull is similar in all populations, but shape differences are observed in the front portion of the skull; (3) Black Sea males and females have wider and longer rostra (as measured by rostrum length and width, and tip of rostrum to external nares relative to skull length); (4) Black Sea males have wider skulls (as measured by pre-orbital, zygomatic, post-orbital and parietal widths relative to skull length); (5) Black Sea males and females have proportionally smaller orbital length, smaller internal nares and condylar widths and larger occipital ridges.

## DISCUSSION

It is widely recognized that the abundance of harbour porpoises in the Black Sea has declined in the last century due to cetacean fisheries, and that currently, the persistence of this population is threatened by pollution and fisheries by-catch (e.g. IWC 2004). For example, contamination and long term accumulation of DDTs, polychlorinated biphenyls (PCB) and hexachlorocyclohexanes (HCH) are elevated in tissues of Black Sea harbour porpoises, which can impact fecundity (e.g. Tanabe et al. 1997). The Black Sea and more generally, harbour porpoises from the eastern region are on their own evolutionary trajectory, with unique morphological traits and historic divergence from Atlantic populations. This result corroborates that of Tolley & Rosel (2006) who also found significant genetic divergence between 9 Black Sea harbor porpoises and those from West Africa, Portugal and Spain. Thus, we suggest that governmental and conservation agencies implement specific management plans for harbour porpoises of the whole eastern region (Sea of Azov, Black Sea, Sea of Marmara and the northern Aegean Sea).

### Population history and population parameter estimates

The consensus of our genetic analyses is that eastern region harbour porpoises (including those in the Black Sea) became isolated long before recent anthropogenic impacts on the Black Sea. Previous studies suggested that the present degree of water exchange between the Mediterranean and the Sea of Marmara is comparable to that prior to the last interglacial maximum 150 000 yr BP (Yaltirak et al. 2002). The Sea of

Marmara became isolated as a brackish water lake for the first time approximately 150 000 yr BP, was subsequently reconnected with the Mediterranean Sea, and was isolated again during the last glacial maximum ~21 000 yr BP (Yaltirak et al. 2002). Little is known of the Black Sea-Marmara Sea connection between 150 000 and 21 000 yr BP. Between 9000 and 7000 yr BP, the Black Sea was likely a brackish water lake flowing into the Mediterranean Sea (e.g. Aksu et al. 1999, Yaltirak et al. 2002), and marine waters from the Mediterranean were estimated to enter the Black Sea 7150 yr BP (Aksu et al. 1999). If the molecular divergence rate is calibrated to 7150 yr BP, the maximum likelihood estimate of mutation rate would be 41.2% per million years (95Lo–95Hi: 22–140%), which surpasses any rate found in the animal kingdom. Similar calculations using a divergence time dating of the last glacial maximum (~21 000 yr BP) suggest a mutation rate of 13.8% (95Lo–95Hi: 7.5–47%). Consequently, it seems likely that divergence of gene pools between the eastern region and the Atlantic began prior to colonization of the Black Sea, with the most reasonable estimates between 582 418 and 21 000 yr BP.

It is possible that harbour porpoises entered the Marmara Sea and possibly the Black Sea prior to their isolation 150 000 yr BP and/or 21 000 yr BP. Further west, we hypothesize that harbour porpoises colonized the Mediterranean Sea sometime during the second half of the Pleistocene (600 000 to 21 000 yr BP) and had limited exchange with Atlantic populations after that time. Harbour porpoises expanded their range to the eastern Mediterranean where increasing sea temperatures (Chondrogianni et al. 2004) facilitated their recent colonization of the Black Sea 7000 to 5000 yr BP. However, it is not possible to test this scenario directly, because harbour porpoises have now disappeared from the Mediterranean. Moreover, our data do not allow scenarios of multiple colonization events to be easily distinguished from a single unique founder event with subsequent isolation. Further, because we could not thoroughly sample all potential source populations, the exact geographic origin of the colonists cannot be determined.

Maximum likelihood estimate for recent effective population size varied between 27 636 and 386 905 ind. for the eastern populations. Even if estimates using 0.5 and 7% per million years are not very precise, they are much lower than reported quotas of cetaceans killed by fisheries during the last century (e.g. Danilevsky & Tuyutyunnikov 1968). Turkey alone was reported to kill 85 000 to 100 000 cetaceans per year (note that this is census population size), and porpoises became the primary catch in years preceding the prohibition (Danilevsky & Tuyutyunnikov 1968). These results are consistent with the widely accepted assumption that

the Black Sea harbour porpoise population has significantly decreased during the past 100 yr. The 3 unique haplotypes found in the Sea of Marmara are unlikely to be related individuals because they were collected during 3 separate months in 2004. This suggests that the porpoise population in the Sea of Marmara may be genetically differentiated from those in the Black Sea and northern Aegean Sea due to its geographic isolation. However, more detailed conclusions regarding the Marmara population and the exact location of geographic barriers require additional sampling from the Sea of Marmara and the northern Aegean Sea.

### Morphology

We found that Black Sea porpoises display unique cranial characteristics that distinguish them from those of other oceans with 100% classification success. In contrast, previous studies achieved  $\leq 72\%$  correct classification (e.g. Börjesson & Berggren 1997). It has been documented that diet was significantly correlated with adaptive morphological features (e.g. Perrin 1984). The rostrum in particular is known to have very plastic proportions directly related to feeding habits. Rostrum length and width in *Tursiops truncatus* vary between coastal, benthic-feeding dolphins which display more robust rostra (shorter and wider at base) and pelagic ecotypes (characterized by longer and narrower rostra) that feed on schools of small pelagic fish (e.g. Perrin 1984). The proportionally longer and wider rostrum of Black Sea porpoises might be an adaptation to their seasonal feeding habit on pelagic schools of anchovy throughout the winter (Gol'din 2004b) and their main diet of benthic gobies (Zalkin 1940). Black Sea porpoises also mature sexually and attain asymptotic total length at an earlier age than their congeners in the Atlantic which might account for smaller skull size and other smaller proportions (P. Gol'din & A. Galatius pers. comm.). Thus, variation in developmental patterns along with environmental constraints might have led to different body proportions and overall smaller sizes in Black Sea porpoises. However, little is known about developmental differences among populations of harbour porpoises to further explain the observed morphological differences.

### Implications for management, conservation and taxonomy

Population subdivision within the eastern region was suggested by a subtle but statistically significant pattern of isolation by distance within the Black Sea, and unique haplotypes restricted to the Marmara and the

northern Aegean Sea. Further support for this hypothesis was presented by Gol'din (2004b), who demonstrated that Black Sea porpoises are smaller than those in the Sea of Azov. Because nuclear genetic markers do not show statistically significant structure within the Black Sea (M. Fontaine pers. comm.) attempts to quantify these patterns more precisely would require the use of additional markers with high mutation rates, and more samples from the northern Aegean Sea and Sea of Marmara. In addition to our urgent recommendation of specific protection for the whole eastern region, we suggest that the frequency of porpoise migration through the Turkish straits system be estimated. With increasing boat traffic within the strait, porpoises in the northern Aegean Sea and Sea of Marmara could become further isolated from other populations in the region, or even disappear.

In conclusion, there is strong evidence that eastern harbour porpoises have been reproductively isolated for thousands of years and have genetically and morphologically diverged from porpoises from other oceans. The estimate of  $\theta_{ST}$  between eastern and Atlantic porpoises was high, comparable to  $\theta_{ST}$  between the well recognized species *Tursiops truncatus* and *Tursiops aduncus* (Natoli et al. 2004). Consequently, porpoises from the eastern region could be classified at least as subspecies *Phocoena phocoena relicta*, based on Mayr's (1942) biological subspecies concept (which requires reproductive isolation), or a more recent definition by Reeves et al. (2004) which requires demonstration of independent evolution trajectory using morphological evidence or one line of genetic evidence with less than one migrant per generation.

**Acknowledgements.** The authors are grateful to all who kindly provided or facilitated access to samples for genetic analysis and skeletal material for measurements: Dr. L. Holsbeek, Free University of Brussels, Belgium; J. C. Rivilla, Grupo Mamíferos Marinos de la SECEM, Spain; S. Alis, Colectivo GRAMPUS and A. Cañadas, CIESM, Spain; W. Dabin, O. Van Canneyt and staff of the Centre de Recherche sur les Mammifères Marins, France; A. Tonay, Faculty of Fisheries, Istanbul University, Turkey; Participants of the BLASDOL Project (1997–1999); Staff and volunteers of the BREMA Laboratory, and M. V. Yurakhno, V. I. Vernadsky Taurida National University, Simferopol, Ukraine; Institute of Fisheries, Varna, Bulgaria; Institute of Marine Ecology and Fisheries, Batumi, Georgia; M. Andersen and H. J. Baagøe, Zoological Museum, University of Copenhagen, Denmark. We extend our gratitude to Dr. W. Perrin, Dr. P. Van Klaveren, Dr. M. Van Klaveren, Dr. A. Aksu, A. Galatius and Dr. C. C. Kinze for their support and expertise; and to Dr. R. LeDuc, Dr. G. Notarbartolo di Sciarra and an anonymous reviewer for their constructive comments on the manuscript. This project was funded by the Charles A. and Anne Morrow Lindbergh Foundation, and the International Fund for Animal Welfare. All necessary US import permits were provided by the SWFSC.

#### LITERATURE CITED

- Abel O (1905) Eine Stammtypen der Delphiniden aus dem Miocän der Halbinsel Taman. Jahrbuch K K Geolog Reichsanstalt 55:375–392
- Aksu AE, Hiscott RN, Yaflar D (1999) Oscillating quaternary water levels of the Marmara Sea and vigorous outflow into the Aegean Sea from the Marmara Sea-Black Sea drainage corridor. Mar Geol 153:275–302
- Arvy L (1977) Asymmetry in cetaceans. Investig Cetacea 8: 161–220
- Barabash-Nikiforov II (1940) Cetacean fauna of the Black Sea. Its origin and composition. State University of Voronezh, Russia (in Russian)
- Börjesson P, Berggren P (1997) Morphometric comparisons of skulls of harbour porpoises (*Phocoena phocoena*) from the Baltic, Kattegat, and Skagerrak Seas. Can J Zool 75: 280–287
- Chivers SJ, Taylor BL (1997) Probabilities of population dispersal rates inferred from genetic distance data. In: Dizon AE, Chivers SJ, Perrin WF (eds) Molecular genetics of marine mammals (Society for Marine Mammalogy special publication no. 3). Society for Marine Mammalogy, Lawrence, KS, p 365–380
- Chondrogianni C, Ariztegui D, Rolph T, Juggins S and 7 others (2004) Millennial to interannual climate variability in the Mediterranean during the last glacial maximum. Quat Int 122:31–41
- Clement M, Posada D, Crandall KA (2000) TCS: a computer program to estimate gene genealogies. Mol Ecol 9: 1657–1659
- Danilevsky N, Tuyutyunnikov VP (1968) Present state of Black Sea dolphins described. Rybn Khoz 11:25–27
- Excoffier L, Smouse PE, Quattro JM (1992) Analysis of molecular variance inferred from metric distances among DNA haplotypes: application to human mitochondrial DNA data. Genetics 131:479–491
- Frantzis A, Gordon J, Hassidis G, Komnenou A (2001) The enigma of the harbour porpoise presence in the Mediterranean Sea. Mar Mamm Sci 17:937–944
- Galatius A (2005) Sexually dimorphic proportions of the harbour porpoise (*Phocoena phocoena*) skeleton. J Anat 206: 141–154
- Galatius A, Kinze CC (2003) Ankylosis pattern in the postcranial skeleton and hyoid bones of the harbour porpoise (*Phocoena phocoena*) in the Baltic and North Sea. Can J Zool 81:1851–1861
- Galatius A, Andersen MBER, Haugan B, Langhoff HE, Jespersen A (2006) Timing of the epiphyseal development in the flipper skeleton of the harbour porpoise (*Phocoena phocoena*) as an indicator of paedomorphosis. Acta Zool 87:77–82
- Gol'din PE (2004a) Taxonomic status of harbour porpoise (*Phocoena phocoena*) from the Sea of Azov and the Black Sea. In: Belkovitch VM (ed) Marine mammals of the Holarctic: collection of scientific papers after the Third International Conference, Koktebel, Crimea, Ukraine. KMK, Moscow, p 158–162
- Gol'din PE (2004b) Growth and body size of the harbour porpoise, *Phocoena phocoena* (Cetacea, Phocoenidae) in the Sea of Azov and the Black Sea. Vestn Zoo 38(4):59–73
- Harlin AD, Markowitz T, Baker S, Würsig B, Honeycutt RL (2003) Genetic structure, diversity, and historical demography of New Zealand's dusky dolphin (*Lagenorhynchus obscurus*). J Mammal 84:702–717
- Hey J, Nielsen R (2004) Multilocus methods for estimating population sizes, migration rates and divergence time,

- with applications to the divergence of *Drosophila pseudo-obscura* and *D. persimilis*. *Genetics* 167:747–760
- Hoelzel AR, Hancock JM, Dover GA (1991) Evolution of the cetacean mitochondrial D-loop region. *Mol Biol Evol* 8: 475–493
- IWC (2004) Review of status of small cetaceans in the Black Sea. Annex L: Report of the sub-committee on small cetaceans. *J Cetacean Res Manag* 6:315–325
- Jensen JL, Bohonak AJ, Kelley ST (2005) Isolation by distance Web service. *BMC Genet* 6:13
- Kideys AE (1994) Recent dramatic changes in the Black Sea ecosystem: the reason for the sharp decline in the Turkish anchovy fisheries. *J Mar Syst* 5:171–181
- Kleinenberg SE (1978) Mammals of the Black Sea and the Sea of Azov: results of joint biological-commercial dolphin whaling studies. Fisheries and Marine Service translation series no. 4319. Department of the Environment, Fisheries and Marine Service, Ste. Anne de Bellevue, Québec, Canada. (English translation of: Kleinenberg SE. Mlekopotayuschie Chernogo i Azovskogo morei: opyt biologo-promyslovogo issledovaniya. USSR Academy of Sciences Press, Moscow, 1956)
- Knowles LL, Maddison WP (2002) Statistical phylogeography. *Mol Ecol* 11:2623–2635
- Mayr E (1942) Systematics and the origin of species. Columbia University Press, New York
- Natoli A, Peddemors V, Hoelzel AR (2004) Population structure and speciation in the genus *Tursiops* based on microsatellite and mitochondrial DNA analyses. *J Evol Biol* 17:363–375
- Nei M (1987) Molecular evolutionary genetics. Columbia University Press, New York
- Öztürk B, Öztürk AA (1996) On the biology of the Turkish straits system. *Bull Inst Oceanogr Numero Spec* 17: 205–217
- Palsbøl PJ, Bérubé M, Aguilar A, Notarbartolo di Sciara G, Nielsen R (2004) Discerning between re-current gene flow and recent divergence under a finite-site mutation model applied to North Atlantic and Mediterranean Sea fin whale (*Balaenoptera physalus*) populations. *Evolution* 58:670–675
- Perrin WF (1984) Pattern of geographical variation in small cetaceans. *Acta Zool Fenn* 172:137–140
- Perrin WF, Heyning JE (1993) Rostral fusion as a criterion of cranial maturity in the common dolphin, *Delphinus delphis*. *Mar Mamm Sci* 9:195–197
- Posada D, Crandall KA (1998) MODELTEST: testing the model of DNA substitution. *Bioinformatics* 14:817–818
- Posada D, Crandall KA (2001) Intraspecific gene genealogies: trees grafting into networks. *Trends Ecol Evol* 16(1):37–45
- Posada D, Crandall KA, Templeton AR (2000) GeoDis: A program for the cladistic nested analysis of the geographical distribution of genetic haplotypes. *Mol Ecol* 9:487–488
- Reeves RR, Perrin WF, Taylor BL, Baker CS, Mesnick SL (2004) Report of the workshop on shortcomings of cetacean taxonomy in relation to needs of conservation and management. NOAA Technical Memorandum NMFS, NMFS-SWFSC-363
- Rosel PE, Dizon AE, Haygood MG (1995) Variability of the mitochondrial control region in populations of the harbour porpoise, *Phocoena phocoena*, on interoceanic and regional scales. *Can J Fish Aquat Sci* 52: 1210–1219
- Rosel PE, Tiedemann R, Walton M (1999) Genetic evidence for limited trans-Atlantic movements of the harbour porpoise *Phocoena phocoena*. *Mar Biol* 133:583–591
- Rosel PE, Frantzis A, Lockyer C, Kommenou A (2003) Source of Aegean Sea harbour porpoises. *Mar Ecol Prog Ser* 247: 257–261
- Schneider S, Roessli D, Excoffier L (2001) Arlequin v. 2.0: A software for population genetic data analysis. Genetic and Biometry Laboratory, University of Geneva
- Strauss RE, Atanassov MN, De Oliveira JA (2003) Evaluation of the principal component and expectation maximization methods for estimating missing data in morphometric studies. *J Vertebr Paleontol* 23:284–296
- Swofford DL (1998) PAUP\* 4.0: Phylogenetic Analysis Using Parsimony (\*and Other Methods). Sinauer Association, Sunderland, MA
- Tanabe S, Madhusree B, Öztürk AA, Tatsukawa R and 5 others (1997) Isomer-specific analysis of polychlorinated biphenyls in harbour porpoise (*Phocoena phocoena*) from the Black Sea. *Mar Pollut Bull* 34(9):712–720
- Templeton AR (1998) Nested clade analyses of phylogeographic data: testing hypotheses about gene flow and population history. *Mol Ecol* 7:413–418
- Templeton AR (2004) Statistical phylogeography: methods of evaluating and minimizing inference errors. *Mol Ecol* 13: 789–809
- Tolley KA, Rosel PE (2006) Population structure and historical demography of Eastern North Atlantic harbour porpoises inferred through mtDNA sequences. *Mar Ecol Prog Ser* 327:297–308
- Tolley KA, Vikingsson GA, Rosel PE (2001) Mitochondrial DNA sequence variation and phylogeographic patterns in harbour porpoises (*Phocoena phocoena*) from the North Atlantic. *Conserv Genet* 2:349–361
- Yaltirak C, Sakinç M, Aksu AE, Hiscott RN, Galle B, Ulgen UB (2002) Late Pleistocene uplift history along the southwestern Marmara Sea determined from raised coastal deposits and global sea-level variations. *Mar Geol* 190: 283–305
- Zalkin VI (1938) Morphological characteristics, taxonomic status and zoogeographical status of the harbour porpoise in the Sea of Azov and the Black Sea. *Zool Zh* 17:706–733 (in Russian)
- Zalkin VI (1940) Materials on life history of harbour porpoise (*Phocoena phocoena relicta* Abel) from the Sea of Azov and the Black Sea. *Zool Zh* 19:160–171 (in Russian)

Editorial responsibility: Otto Kinne (Editor-in-Chief)  
Oldendorf/Luhe, Germany

Submitted: August 15, 2006; Accepted: October 19, 2006  
Proofs received from author(s): May 4, 2007