



Coastal silicon cycling amplified by oyster aquaculture

Nicholas E. Ray^{1,2,*}, Alia N. Al-Hajj³, Timothy J. Maguire^{1,4}, Maria C. Henning³,
Robinson W. Fulweiler^{1,3}

¹Department of Biology, Boston University, Boston, MA 02215, USA

²Department of Ecology & Evolutionary Biology, Cornell University, Ithaca, NY 14853, USA

³Department of Earth & Environment, Boston University, Boston, MA 02215, USA

⁴Cooperative Institute for Great Lakes Research, University of Michigan, Ann Arbor, MI 48109, USA

ABSTRACT: Filter-feeders play an important role in regulating nutrient availability in coastal systems, with important implications for phytoplankton community composition, primary production, and food web structure. The role of filter-feeding bivalves in the nitrogen and phosphorus cycles is relatively well established, but their impact on coastal silicon (Si) cycling remains poorly understood. To help reduce this uncertainty, we quantified rates of Si recycling and the size of various Si pools at an oyster (*Crassostrea virginica*) farm. We found that oysters drive rapid recycling of dissolved Si (DSi) to the water column, primarily by altering rates of sediment Si flux. Sediments beneath oyster aquaculture recycled DSi to the water column at more than twice the rate ($2476.06 \mu\text{mol DSi m}^{-2} \text{h}^{-1}$) of nearby bare sediments ($998.75 \mu\text{mol DSi m}^{-2} \text{h}^{-1}$). Oysters consume DSi at a low rate ($-0.06 \mu\text{mol DSi ind.}^{-1} \text{h}^{-1}$), and, while we were unable to determine the fate of that Si, we hypothesize that at least some of it may be stored in the shell and tissue, which are both small Si pools (0.55 and 0.13 % Si by mass respectively). Si held in oysters is removed from the system when oysters are harvested, but this removal is small compared to oyster-mediated enhancements in sediment Si recycling. In a broader context, coastal systems with larger oyster populations are likely to have a more rapid Si cycle, with more Si available to primary producers in the water column than those with no oysters.

KEY WORDS: Oyster · Silicon · Aquaculture · Coastal biogeochemistry

1. INTRODUCTION

Filter-feeders play an important role in regulating the biogeochemistry, and thus ecology of aquatic ecosystems (Newell 1988, Li et al. 2021). Suspension-feeding bivalves alter biogeochemical cycles by consuming particulate nutrients from the water column, excreting dissolved nutrients, and providing habitat for biofilms on their shells (Galtsoff 1964, Sma & Baggaley 1976, Prins et al. 1997, Welsh & Castadelli 2004, Svenningsen et al. 2012). Through biodeposition, oysters also increase organic matter (OM) availability in the sediments, which can stimulate sediment micro-

bial processes that lead to higher rates of nutrient recycling and removal of excess nitrogen (N) via denitrification (Newell et al. 2005, Kellogg et al. 2013, Ray & Fulweiler 2021). The ecological feedbacks of bivalve-mediated nutrient recycling in coastal oceans include higher productivity (Prins et al. 1997, Peterson & Heck 1999, Wall et al. 2008), regulation and alteration of phytoplankton community structure (Porter et al. 2018, 2020), and increased nutrient export (Dame et al. 1984, 1991, 1992).

Many coastal systems were once home to large populations of oysters, although following centuries of over-harvest, pollution, and disease, these popula-

*Corresponding author: ner35@cornell.edu

tions have been reduced to a fraction of their former extent (Mackenzie 2007, Beck et al. 2011, Zu Ermgassen et al. 2012). When populations of suspension-feeding oysters were lost, so were the ecosystem services they provided. There are recent efforts to grow oyster populations—in part to return lost ecosystem services—through the development of aquaculture and by reconstructing and restoring reefs (Duarte et al. 2020, FAO 2020). A large body of research demonstrates enhanced recycling of dissolved N and phosphorus (P) alongside removal of excess N via denitrification in oyster habitats, but the role oysters may play in regulating silicon (Si) cycling in coastal ecosystems has largely gone unexplored (Dame 2012, Ray & Fulweiler 2021). The potential impact of oysters on estuarine Si cycling is important, as Si availability can regulate phytoplankton community composition (Egge & Aksnes 1992, Turner et al. 1998), primary production (Dugdale et al. 1995, Dugdale & Wilkerson 1998), and food web structure (Doering et al. 1989, Turner et al. 1998). On larger spatial and temporal scales, Si export from coastal ecosystems contributes to Si availability in the ocean and helps to control the magnitude of the biological pump and global climate (Tréguer & Pondaven 2000, Ragueneau et al. 2006). Thus, the role oysters and other suspension-feeders play in coastal Si cycling may have both local and far-reaching effects.

Despite the potential importance of oysters in the coastal Si cycle, we have a limited understanding of how they might alter it. Oysters could promote greater Si availability through Si excretion and stimulation of sediment Si regeneration. Alternatively, oysters might reduce Si availability and export through sequestration in shell and tissue and by promoting burial of Si in sediment. There is some evidence that dissolved Si (DSi) fluxes from sediments to the water column are higher in oyster habitats compared to adjacent bare sediments (Smaal & Prins 1993, Gaertner-Mazouni et al. 2012, Green et al. 2013). A similar pattern has been noted for other suspension feeders including clams (*Mercenaria mercenaria*: Doering et al. 1987; *Tapes philippinarum*: Bartoli et al. 2001) mussels (*Mytilus edulis*: Dame et al. 1991, Smaal & Prins 1993), and slipper shells (*Crepidula fornicata*: Chauvaud et al. 2000, Ragueneau et al. 2002). It may be possible that the length of time bivalves have been present in a specific location could influence sediment Si regeneration as Si-containing biodeposits accumulate and decompose. There is scarce evidence regarding excretion of DSi by bivalves, though Asmus et al. (1990) reported direct excretion by mussels *M. edulis*. We could not locate

any information in regards to burial of Si in oyster habitats, but oysters do sequester a small amount of Si in their shell (Brown & Koiner 1889, Hunter & Harrison 1928, Smith & Wright 1962, Galtsoff et al. 1964). We found no reports of oyster tissue Si content. Any Si held in oyster shell or tissue is removed from the system at harvest or possibly buried, in both instances removing Si from the system.

To address the uncertainties in Si cycling associated with oysters and to clarify the role of oysters in coastal Si cycling, we performed a series of incubations to measure rates of DSi flux from sediments beneath varying ages of oyster aquaculture for comparison with nearby bare sediment using an *in situ* approach. We performed laboratory incubations to measure DSi fluxes from whole oysters, the oyster shell biofilm, and the oyster digestive system. We also measured the amount of Si stored in sediments beneath oyster aquaculture as amorphous Si (ASi; the combination of biogenic Si and the non-mineral pedogenic Si fraction; Sauer et al. 2006) and porewater DSi as well as the ASi content of tissue from market-size oysters *Crassostrea virginica*. We consider oyster biomass as ASi in this study, as we are unable to differentiate between Si held in oyster tissue and any Si that may be held in the oyster digestive system of potentially pedogenic origin. Finally, we estimated the ASi content in the shell of market-size oysters using values found in the literature.

2. MATERIALS AND METHODS

2.1. Study site

We measured sediment DSi fluxes using an *in situ* approach and collected sediment and oyster samples at an oyster farm in Ninigret Pond, Rhode Island, USA (41.3576° N, 71.6534° E; Fig. S1 in the Supplement at www.int-res.com/articles/suppl/m673p029_supp.pdf). Ninigret Pond is a shallow (1.2 m average depth) glacially formed coastal lagoon, with a surface area of 6.4 km² and water residence time of approximately 10 d (Boothroyd et al. 1985, Lee & Olsen 1985, Hougham & Moran 2007). Freshwater inflow to the pond is mainly from ground-water discharge (0.39 m³ s⁻¹) and stream water (0.16 m³ s⁻¹; Masterson et al. 2007). The oyster farm is located on subtidal flats on the interior of the barrier spit that separates Ninigret Pond from Block Island Sound. The farm employs the rack-and-bag culture method, where oysters are raised in cages approximately 10–20 cm above the sediment surface. We sampled from 3 locations within the farm

and a control site 10 m upstream of the farm that had never been used for oyster culture. The 3 locations within the farm had been used for aquaculture for varying lengths of time (2, 4, and 6 yr in 2014; 3, 5, and 7 yr in 2015), so over our 2 yr sampling regime we were able to investigate potential relationships between length of time aquaculture has been in place and Si cycling dynamics. We used oysters from the farm in laboratory incubations to measure DSi fluxes from oysters and assessment of oyster tissue ASi content.

We recorded water temperature and dissolved oxygen (DO) directly adjacent to the site throughout the 2 sampling seasons using HOBO Pendant data loggers and a HOBO Dissolved Oxygen Data Logger (Onset Computer Corporation), both set to record every 15 min. Additionally, we measured salinity, DO, and water temperature hourly on sampling days using a Hach HQ40d (Table S1).

2.2. Sediment DSi flux measurements

We measured sediment DSi flux using an *in situ* approach in summer 2014 and 2015 (Humphries et al. 2016, Ray et al. 2020). This method involves installing permanent bases in the sediment, to which water- and gas-tight incubation chambers are attached for sampling events (Fig. 1). We installed 9 bases in sediment directly beneath oyster aquaculture gear and 3 upstream of the aquaculture facility for the control site in June 2014. To install the bases, we carefully dug up sediment, placed the base in the benthos, and replaced the removed sediment into the base, careful to try and maintain sediment structure (for full details, see Humphries et al. 2016). The bases were made of 40.6 cm diameter PVC (0.126 m² area), with 24 bolts to which the incubation chamber was attached for sampling events. They were 15 cm deep with a solid bottom, allowing us to exclude the possibility of groundwater-driven differences in sediment DSi flux. Bases were left for at least 1 mo before sampling to allow for the sediment to return to pre-installation condition (Kellogg et al. 2013). Control site bases were initially installed in water too shallow so were moved, resulting in the collection of only 2 control samples of DSi flux in summer 2014.

On sampling days, we moved the oyster aquaculture gear from over the base then attached incubation chambers. Each incubation chamber (approximately 47 l volume) was made of plexiglass wrapped with dark bubble-wrap insulation, with a removable lid equipped with a stir arm to maintain even mixing of water within the chamber. The incubation cham-

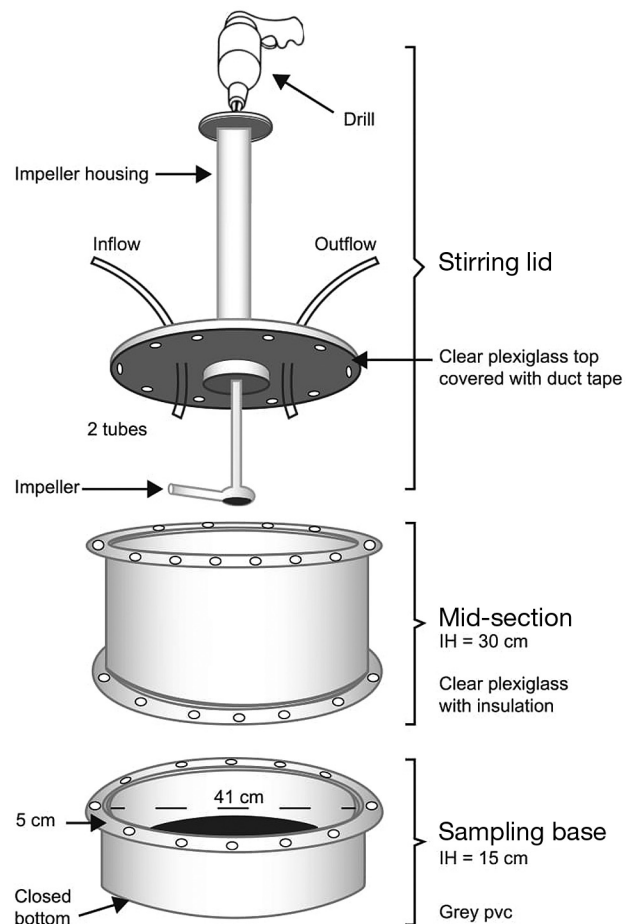

Fig. 1. *In situ* sampling chamber design, reprinted from Humphries et al. (2016). Copyright 2016 by the authors and open access under Creative Commons Attribution License (CC BY) via Frontiers of Marine Science

ber was attached by first placing a rubber gasket on the base and then attaching the chamber to the base with wing nuts. We then installed a HOBO pendant logger in the sediment inside the chamber to ensure light and temperature remained constant through the incubation and then attached the lid, making sure there were no bubbles in the chamber. Once the lid was attached, we placed a black plastic top over it and started the stir arm (~60–70 revolutions min⁻¹). Chamber lids had an inflow and outflow tube fitted with valves. During sample collection, site water was fed into the chamber to create a slight pressure differential and to push water out of the outflow tube for sample collection. Less than 1% of water in the chamber was replaced during each incubation, and incubations lasted 1.5–3 h.

Samples were collected at 5 time points, spaced to allow the DO level within the chamber to drop by at least 2.0 mg l⁻¹ without becoming hypoxic. At each

time point we collected samples by filling a 60 ml acid-washed polypropylene syringe from the outflow tubing and then filtering the sample through a 0.45 μm nitrocellulose filter into two 30 ml acid-washed and deionized-water-leached polyethylene containers. Samples were stored in a dark cooler until return to the lab, at which point they were stored in the dark at room temperature ($\sim 20^\circ\text{C}$) until analysis of DSi concentration. DSi samples were never frozen. We checked the DO concentration throughout the incubation using a Hach HQd equipped with an LDO101 DO sensor by collecting 40 ml of sample through the outflow port, and we used the initial and final DO concentrations to determine sediment O_2 flux.

We estimated DSi flux using linear regressions of change in DSi concentration over time. The slope of the regression was then multiplied by the chamber volume and divided by its cross-sectional area. Fluxes were considered significant at $p \leq 0.10$ and $R^2 \geq 0.65$ (Prairie 1996, Ray et al. 2020), and insignificant fluxes ($R^2 < 0.65$) were assigned a flux value of 0. O_2 fluxes were calculated using the difference between initial and final concentrations.

2.3. Sediment porewater DSi measurements

Porewater was collected from sediments directly adjacent to the sampling base following flux incubations on 2 occasions in 2015 (August and September) from 4 cm depth using methods developed for sandy sediments (Berg & McGlathery 2001). We collected two 25 ml samples from each site by drawing porewater through a 2 mm stainless steel tube using suction applied by a 60 ml acid-washed polypropylene syringe, then immediately filtered the porewater through 0.45 μm nitrocellulose filters into 30 ml acid-washed and deionized-water-leached polyethylene containers. Samples were stored as described for those collected during sediment DSi flux measurements. There was likely influence of groundwater on porewater DSi measurements, as they were taken outside of the benthic rings, but any difference in concentration between bare sediments and those beneath aquaculture can still be attributed to oyster presence.

2.4. Sediment ASi content

We collected sediment samples from within each benthic ring following incubations in August and September 2015 using a 60 ml acid-washed poly-

propylene syringe with the tip cut off. Sub-samples at 0–1 and 3–4 cm depth increments were sectioned into acid-washed polypropylene centrifuge tubes which were placed on ice until return to the lab, where they were stored at -20°C until further analysis. These samples were later analyzed for bulk density, porosity, ASi content, and percent OM content (%OM).

We determined sediment bulk density by water displacement, porosity as the difference in mass between wet and dry sediment divided by the sediment density, and %OM as the percent difference in dried and ground sediment mass before and after combustion in a 500°C muffle furnace for 4 h (Table S2) (Dalsgaard et al. 2000). Once dried, the sediment used to measure porosity was ground using a ball mill (Wig-L Bug, Dentsply Rinn) to prepare for ASi analysis. Ground samples were digested in duplicate using a wet alkaline extraction method to determine ASi content (Conley 1998). Briefly, samples were leached with 40 ml 1% Na_2CO_3 solution and placed in an 85°C water bath shaking at 100 rpm. Subsamples (1 ml) of the leachate were collected at 3, 4, and 5 h and added to 30 ml polyethylene containers containing 9 ml of 0.021 N hydrochloric acid in order to neutralize the reaction (DeMaster 1981, Conley & Schelske 2001). These samples were analyzed using the colorimetric method described below, and sediment ASi content was calculated as:

$$\text{ASi (\% SiO}_2) = \frac{\mu\text{m DSi} \times 60 \text{ g mol}^{-1} \times 0.04 \text{ l}}{\text{mg sediment digested}}$$

To account for (and exclude) possible lithogenic Si released into solution during the wet alkaline extraction, we used a slope correction (DeMaster 1981, Conley 1998). If least squares regression indicated a significant increase in ASi concentration between the 3 time points ($p \leq 0.05$, $R^2 \geq 0.65$) for each sediment sample, we extrapolated to the intercept and used that value as our ASi concentration. When there was not a significant increase, we considered the sediment ASi content to equal the mean of the 3 samples (Conley 1998, Sauer et al. 2006). We used an internal laboratory standard to ensure consistency across digestions, which we routinely compared with external Hach standards. Our standards were always within 4% of the expected value (Carey & Fulweiler 2014). We report all ASi values as % SiO_2 per dry weight.

2.5. Oyster DSi flux

We collected oysters and carboys of unfiltered site water on 3 occasions in summer 2015. Oysters were

kept submerged in site water in a cooler until return to the lab, at which point they were moved to an environmental chamber set to the same *in situ* temperature, and the water in the cooler was replaced and gently aerated using an aquarium bubbler.

Within 24 h, we conducted flux incubations similar to the *in situ* incubations, using a similar but smaller incubation chamber (28 cm high, 2.15 l) made of clear PVC tubing with a flat base. Each incubation consisted of 12 total chambers: 3 chambers with site water only to account for any water column consumption or production of DSi, 3 chambers containing 4 untreated oysters each, 3 chambers with 4 oysters with no shell biofilm, and 3 chambers with 4 sets of shells with an intact shell biofilm but no oyster tissue (Ray et al. 2019). We used this approach to quantify the role of the shell biofilm and oyster digestive system in DSi cycling. To remove the shell biofilm, we scrubbed oysters with a soft plastic bristle brush for 3 min, soaked them for 5 min in 31 salinity artificial seawater (ASW), bathed them in 2.5% household bleach in 31 salinity ASW for 5 min, rinsed them clean with Mili-Q water, and kept them in 31 salinity ASW until the start of the incubation (Tamburri et al. 1992, Ray et al. 2019). This experimental design allowed us to quantify fluxes from whole, untreated oysters, and attempt to determine whether the oyster itself or the shell epibiont community drove the whole oyster flux. We visually checked that all oysters were open and feeding before beginning sample collection, and tested for any remnant chlorine from the bleach treatment using a Hach Model CN-66T chlorine test kit. All oysters were open during each incubation, and we recorded no chlorine in any incubation chamber. Samples for DSi were collected prior to capping the chambers and following removal of the cap. The length of the incubation was again timed so DO in the chamber could drop at least 2.0 mg l⁻¹ without the DO level falling below the hypoxic threshold of 2.0 mg l⁻¹. Lights in the environmental chamber were left on during the course of the incubations, which lasted 2–3.5 h.

Oyster DSi flux was estimated by first subtracting the mean flux in the site water only chambers (μmol l⁻¹ h⁻¹) from the flux of chambers containing oysters. We then converted the rate to a flux per individual oyster by multiplying by the chamber volume and dividing by the number of oysters (4 individuals). There was no difference in oyster size metrics across incubation treatments, but oysters used in the third incubation were slightly heavier and larger than the first 2 incubations. Across incubations, the average oyster had a combined shell and tissue wet weight of

47.67 ± 0.85 g (mean ± SE), shell length of 7.51 ± 0.07 cm, shell width of 5.00 ± 0.07 cm, and shell height of 1.86 ± 0.03 cm (Ray et al. 2019). The average dry tissue mass was 2.93 ± 0.05 g ind.⁻¹.

2.6. Oyster shell and tissue ASi content

We haphazardly selected 12 oysters from the third laboratory incubation for analysis. Dried oyster tissue was ground using a ball mill and stored in plastic scintillation vials until ASi analysis. We measured tissue ASi content following the same methods described for measuring sediment ASi content, but instead of collecting subsamples at 3, 4, and 5 h, we collected one sample following a 4 h incubation (Conley & Schelske 2001). We estimated shell ASi content using values from the literature (Brown & Koener 1889, Hunter & Harrison 1928, Smith & Wright 1962, Galtsoff 1964).

2.7. Colorimetric analysis of Si

All samples were analyzed for DSi concentration using the molybdenum blue colorimetric method on a Seal AA3 auto-analyzer, with sodium hexafluorosilicate (Na₂SiF₆) as the silicate standard (Strickland & Parsons 1968). Throughout our analysis, the lab minimum detection limit was 0.030 μmol l⁻¹. DSi from the alkaline extraction samples to determine ASi and ASi content were analyzed using this same method.

2.8. Statistical analysis

We conducted all statistical analyses using R statistical software version 3.3.2 and the 'lme4' (Bates et al. 2015), 'fitdistrplus' (Delignette-Muller et al. 2015), and 'emmeans' (Lenth 2018) packages. Statistical tests were considered significant at p ≤ 0.05. To test whether sediment DSi and DO fluxes, porewater DSi concentration, and sediment ASi concentration (% mass as Si) and total ASi (μmol cm⁻³) differed between bare sediment and sediment beneath oyster aquaculture, we used a mixed model approach. For each variable measured, we began model selection by determining data distribution using the 'fitdistrplus' package (Delignette-Muller et al. 2015) and transformed data sets as necessary to best meet the assumptions of mixed models (Bolker et al. 2009). Next, we created 8 generalized linear models (GLMs) and 8 generalized linear mixed models (GLMMs) to describe the flux. We only sampled Si pools twice, so we used month in

our models and not the sampling ring as a random effect. In the GLMs, we included the presence or absence of oyster aquaculture as a fixed effect, as well as all possible combinations of temperature, salinity, and sampling monthly as fixed effects. We repeated this process to create GLMMs using the same combination of fixed effects, but with the addition of individual sampling ring as a random effect, allowing us to test whether repeated sampling of the same ring influenced our measurements, and if so, to account for this repetition in our statistical analysis (Ray et al. 2020). We then compared all models created for each pool or flux using Aikake's information criterion (AIC). We compared the 2 models with the lowest AIC using a likelihood ratio test. When the test indicated one model was significantly better than the other, we used it. If the 2 models with the lowest AIC were not significantly different, we elected to use the simpler, more parsimonious model (Table S3).

Following model selection, we used least-square means to test whether pools and fluxes were significantly different between sites with and without oyster aquaculture. To determine whether site age influenced Si and O₂ dynamics, we repeated this process using site age in place of the presence or absence of oyster aquaculture in our models. To test for relationships between DSi flux and porewater DSi concentration and between DSi flux and O₂ flux, we used linear regressions.

We tested whether DSi fluxes from whole oysters, the shell biofilm, or oyster digestive system were significantly different from zero using a 1-sample *t*-test. To compare if DSi flux differed between treatments, we created a GLMM with treatment as a fixed effect and incubation date as a random effect, then compared between treatments using a least square means test.

3. RESULTS

3.1. Sediment Si pools and fluxes

Sediments beneath oyster aquaculture released DSi to the water column ($2476.06 \pm 503.01 \mu\text{mol DSi m}^{-2} \text{h}^{-1}$) at more than twice the rate of bare sedi-

ment ($998.75 \pm 594.05 \mu\text{mol DSi m}^{-2} \text{h}^{-1}$; $z = 2.833$, $df = 47$, $p = 0.005$; Fig. 2). Similarly, the concentration of DSi in sediment porewater at 4 cm depth was higher in sediment beneath aquaculture ($262.87 \pm 39.21 \mu\text{mol DSi l}^{-1}$) than nearby bare sediments ($105.59 \pm 27.84 \mu\text{mol DSi l}^{-1}$; $z = 2.312$, $df = 17$, $p = 0.021$; Fig. 3). Both DSi flux and porewater DSi appeared to increase with the length of time aquaculture had been in place (Fig. 2), though not significantly so. There was a significant relationship between porewater DSi concentration and sediment DSi flux ($R^2 = 0.30$, $F = 8.242$, $p = 0.010$; Fig. 3).

Sediment O₂ consumption was no different ($t = 0.614$, $df = 51$, $p = 0.542$) beneath aquaculture ($-30468.23 \pm 4102.60 \mu\text{mol O}_2 \text{m}^{-2} \text{h}^{-1}$) or bare sediment ($-19922.33 \pm 3536.63 \mu\text{mol O}_2 \text{m}^{-2} \text{h}^{-1}$; Fig. 2), but was temporarily enhanced in sediments beneath

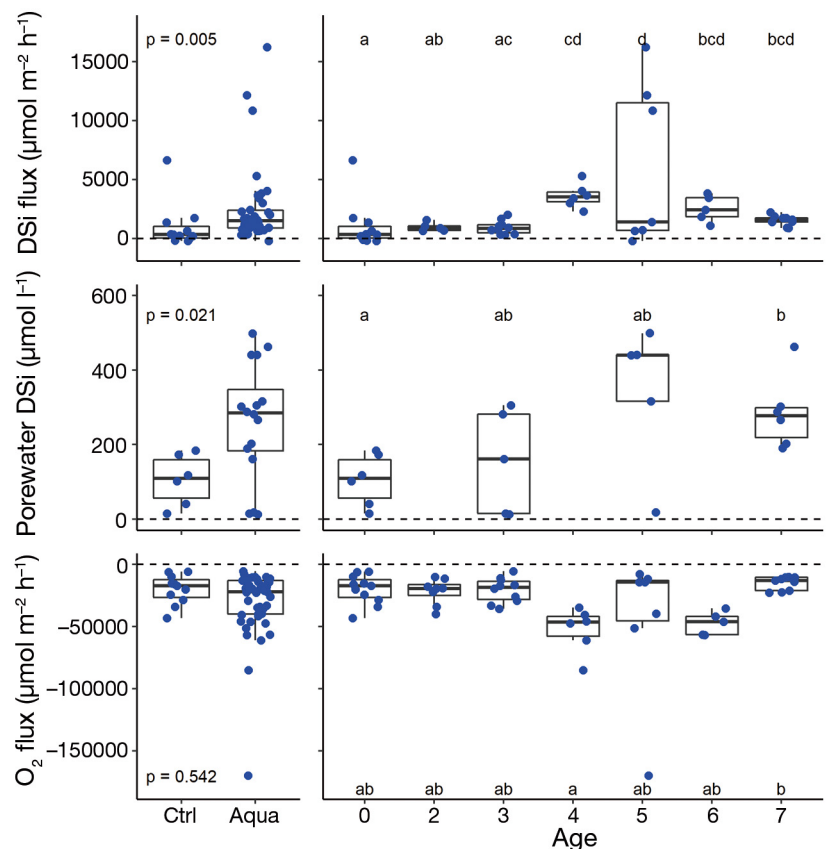

Fig. 2. Dissolved silicon (DSi) fluxes (top), porewater DSi concentration (4 cm depth; middle), and dissolved oxygen consumption (bottom) from bare sediments (Ctrl) and sediments beneath oyster aquaculture gear (Aqua) and different ages of aquaculture (years in place). The p-values are from least square means tests of generalized linear models (left column); groups with the same letter are not significantly different from each other (right column; pairwise comparisons in Table S4). Each point indicates a single measurement. Solid line in the middle of each box: median; lower and upper edges of each box: 25th and 75th percentiles; end of each whisker: smallest and largest values within 1.5 times the interquartile range

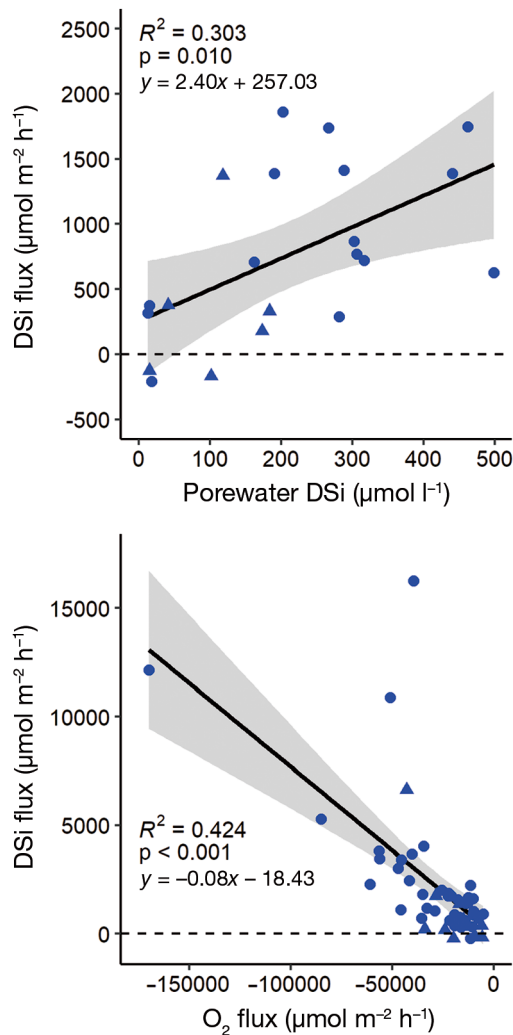

Fig. 3. Linear regressions of the relationship between porewater dissolved silicon (DSi) concentration and DSi flux (top), and sediment O_2 consumption and DSi flux (bottom). Triangles: measurements made at bare sediment; circles: measurements from sediment beneath aquaculture; shaded region: 95% CI

aquaculture in place for 4 yr before returning to baseline conditions. We observed a significant relationship between sediment O_2 consumption and DSi release, with highest rates of DSi recycling when O_2 consumption was greatest ($R^2 = 0.42$, $F = 37.49$, $df = 51$, $p < 0.001$; Fig. 3).

There was no difference in ASi concentrations on the sediment surface (0–1 cm depth; $z = 0.430$, $df = 17$, $p = 0.667$) between bare sediments ($0.70 \pm 0.12\%$ ASi) and sediments beneath aquaculture ($0.96 \pm 0.13\%$ ASi). However, surface ASi concentrations varied with aquaculture age, with a decline in ASi concentration at the 3 yr site relative to bare sedi-

ments, and then significantly higher ASi concentration at the 5 and 7 yr sites relative to bare sediment and the 3 yr site ($p < 0.001$ in both cases; Fig. 4, Table S4). ASi concentrations tended to be lower in sediments collected from 3–4 cm depth than surface sediments, and again, we found no difference in ASi concentration at 3–4 cm depth ($t = 1.364$, $df = 18$, $p = 0.189$) between bare sediment ($0.40 \pm 0.03\%$ ASi) and sediments beneath aquaculture ($0.55 \pm 0.06\%$ ASi). ASi concentrations at 3–4 cm depth followed a similar pattern of increasing concentration with aquaculture age as the top cm of sediment, but differences were less pronounced (Fig. 4).

3.2. Oyster Si pools and fluxes

Untreated oysters consumed DSi at a rate statistically different from zero ($-0.06 \pm 0.03 \mu\text{mol DSi ind.}^{-1} \text{h}^{-1}$; $t = -2.393$, $df = 8$, $p = 0.044$), unlike the shell epibiont ($0.03 \pm 0.03 \mu\text{mol DSi ind.}^{-1} \text{h}^{-1}$; $t = 0.867$, $df = 8$, $p = 0.411$) and oyster digestive system ($0.00 \pm 0.02 \mu\text{mol DSi ind.}^{-1} \text{h}^{-1}$; $t = 0.00$, $df = 8$, $p = 1.00$), neither of which was a net sink or source of DSi (Fig. 5, Table S5).

We determined that dry oyster tissue contains $0.13 \pm 0.01\%$ ASi by mass. To estimate the total mass of ASi in oyster tissue, we multiplied the average dry tissue mass of oysters used in this study (2.93 g ind.^{-1}) by their ASi concentration (0.13%), yielding an average tissue ASi mass of $0.004 \text{ g ASi ind.}^{-1}$ at harvest. We calculated the mass of ASi in oyster shell using shell ASi content values from the literature (0.55% ASi; Table 1) and the average mass of oyster shell measured in this study ($44.74 \text{ g ind.}^{-1}$; estimated as the difference between total oyster mass and dry tissue mass) for an estimate of $0.246 \text{ g ASi ind.}^{-1}$ in shell. Combining tissue and shell ASi, we estimate that a market-size oyster raised in aquaculture contains $0.25 \text{ g ASi ind.}^{-1}$.

4. DISCUSSION

Results of our study make it clear that oysters exert a strong influence on coastal Si cycling. We found that they enhance rates of Si recycling to the water column through stimulation of sediment DSi flux. Oysters may also serve as a Si sink, with Si captured and stored in shell and tissue removed from the system through either oyster harvest or burial of shell material. Ultimately, the balance of oyster-mediated Si recycling and capture will dictate how they influ-

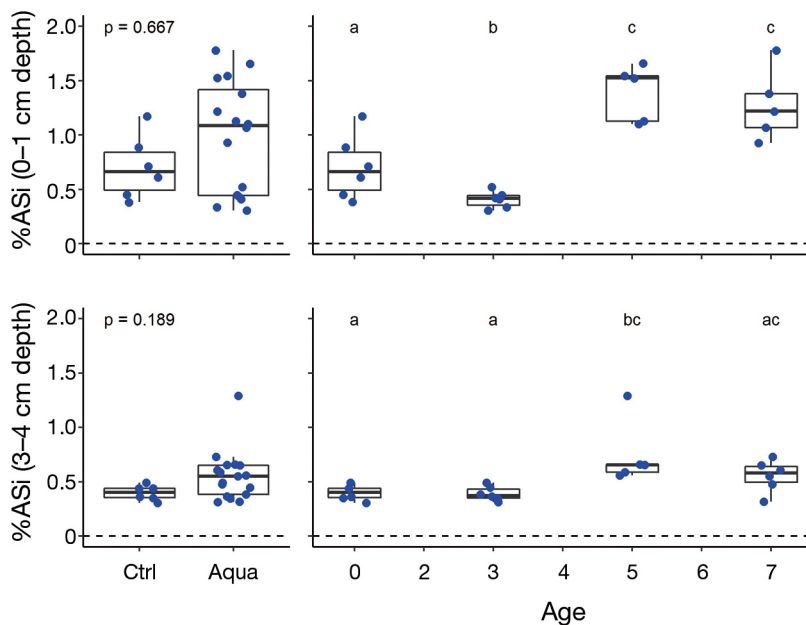

Fig. 4. Sediment amorphous silicon concentration by percent mass (%ASi) in surface (0–1 cm depth; top) and deeper (3–4 cm depth; bottom) from bare sediments (Ctrl) and sediments beneath oyster aquaculture (Aqua; left) and sediments beneath aquaculture for varying lengths of time (right; years in place). The p-values indicate results of least square mean tests; within each plot (right), groups with the same letter are not significantly different from each other following least square means tests (Table S4). Other details as in Fig. 2

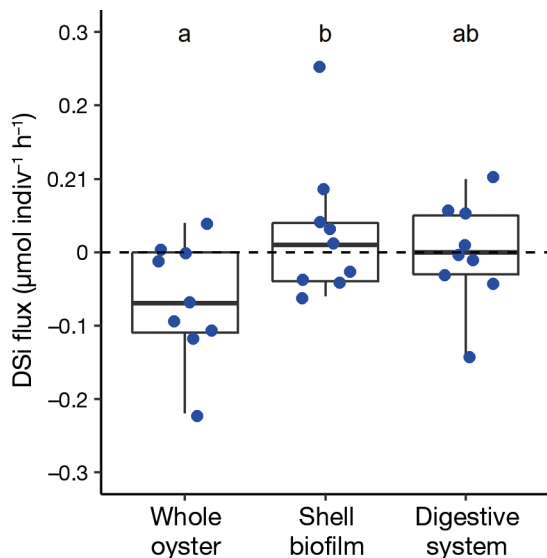

Fig. 5. Dissolved silicon (DSi) fluxes from whole oysters, the oyster shell biofilm, and the oyster digestive tract. Each point represents a single measurement, and groups with the same letter are not significantly different from each other following least square means tests (Table S5). Other details as in Fig. 2

ence coastal Si availability and the impacts this will have on coastal ecology and export of Si to the ocean.

4.1. Oyster aquaculture drives Si recycling

Oyster aquaculture more than doubled rates of sediment DSi flux to the water column, and while the rate of this flux varied with aquaculture age, it tended to increase with time that the aquaculture gear had been in place. We hypothesize several mechanisms that may be responsible for the observed enhancement in sediment DSi flux beneath oysters: (1) higher rates of ASi loading to sediments beneath oysters due to biodeposition, with no change in dissolution rate but higher flux due to more Si-rich substrate; (2) a change in sediment physical or chemical properties that promoted more rapid dissolution of ASi to DSi; and/or (3) alteration of particulates during processing by oysters that allows for them to dissolve more rapidly. There is

some evidence for each of these hypotheses. In support of the first, while we found no statistical difference in surface sediment ASi concentration between bare sediments and those beneath oyster aquaculture, we did measure greater ASi concentrations in surface sediments beneath aquaculture in place for a greater length of time (98 and 81% greater in sediments beneath aquaculture for 5 and 7 yr relative to bare sediments, respectively). We also found that higher DSi fluxes were associated with higher sediment O_2 consumption, lending support to the second hypothesized mechanism. Again, while there were no statistical differences in O_2 flux between bare sediments and aquaculture when all ages of culture

Table 1. Previous estimates of the amorphous silicon content of oyster shell as a percent of total shell mass

Study	Estimated shell SiO_2 content (%)
Brown & Koiner (1889)	0.06
Hunter & Harrison (1928)	0.57–0.58
Smith & Wright (1962)	0.16
Galtsoff (1964)	1.40
Average	0.55

were pooled, there were higher rates of O_2 consumption between some ages of aquaculture relative to bare sediment. Greater biodeposition may have stimulated higher rates of aerobic decomposition, indicated by greater O_2 consumption, exposing more ASi to seawater and allowing it to dissolve. Finally, there is some evidence from the literature in support of the third hypothesis, demonstrating higher Si remineralization rates in oyster feces compared to pseudofeces, and suggesting that passage of particulates through the oyster digestive system promotes dissolution of ASi (Smaal & Prins 1993). An improved understanding of the mechanisms responsible for enhanced DSi recycling beneath oyster aquaculture will determine whether the observations from this study can be assumed in other systems and bivalve species and allow for scaling results.

Return of DSi to the water column by sediments is slightly offset by oyster DSi uptake, but relative to sediment DSi flux, DSi accumulation by oysters is small. For example, at an oyster farm with 500 oysters m^{-2} and an oyster DSi flux of $-0.06 \mu mol ind.^{-1} h^{-1}$, the DSi consumed by the oysters equals $30 \mu mol DSi h^{-1}$, or only 2% of the enhancement in sediment DSi release by oysters ($1477.31 \mu mol m^{-2} h^{-1}$, calculated as the difference in mean sediment DSi flux beneath aquaculture and from bare sediments). We can estimate the relative importance of oyster-mediated DSi recycling in Ninigret Pond using values from the literature to estimate DSi loading to the lagoon and rates of sediment DSi flux measured in this study. Since the incubation chambers we used had closed bottoms and thus were not influenced by groundwater, they allow us to isolate DSi recycling rates. There is no published Si budget for Ninigret Pond, but we can estimate Si loading using reported N loading estimates: 80% of N loaded to Ninigret Pond is from groundwater, with the rest coming from precipitation (9%), offshore water (7%), streams (3%), and runoff (<1%; Lee & Olsen 1985). It is likely that groundwater is also the main source of Si to Ninigret Pond, and groundwater Si loading to the coastal ponds of Rhode Island proceeds at approximately $0.6 mmol DSi m^{-2} h^{-1}$ (Grace & Kelley 1981, Bintz et al. 2003). Bare sediments recycled DSi to the water column at only a slightly higher rate ($1.0 mmol DSi m^{-2} h^{-1}$) than groundwater DSi loading, while sediments beneath oysters recycled DSi to the water column at nearly 4 times ($2.5 mmol m^{-2} h^{-1}$) the rate of groundwater DSi loading. It is clear that adding oysters to coastal systems will lead to more rapid Si cycling and greater availability of Si for phytoplankton.

We expected oysters to release DSi and were surprised to instead measure DSi uptake. Neither the shell epibiont nor the oyster digestive tract alone produced a significant release or uptake of DSi, suggesting that an interactive effect between these 2 microhabitats drives oyster DSi uptake. Oysters excrete dissolved inorganic N and P, and if there were diatoms living in the shell biofilm they may have taken up DSi from the water column alongside dissolved N and P. When the shell epibiont was incubated alone there was no DSi flux, as concentrations of dissolved N and P in the incubation chambers were low (Ray et al. 2019). We recorded no DSi excretion from scrubbed oysters either, likely because they had consumed all of the phytoplankton in the water in the cooler and their digestive system was empty, or possibly due to short retention time of particles within the digestive tract and lack of time for ASi dissolution to occur. As oysters excrete dissolved N and P but not Si, this supports the third hypothesis we presented earlier, where oysters prime fecal biodeposits for Si dissolution in sediments, as they must digest some OM from suspended particulates, thus exposing ASi in biodeposits for dissolution.

The amount of DSi consumed by oysters does not match their ASi content. Assuming the oysters used in this study took 2 yr to reach market size and consumed DSi at the same rate throughout those 2 yr ($0.06 \mu mol DSi ind.^{-1} h^{-1}$), total oyster DSi consumption ($1051.2 \mu mol Si$) makes up only around one-quarter of the ASi in the oyster ($0.25 g ASi ind.^{-1}$, or $4161 \mu mol ASi ind.^{-1}$). One possible explanation for this discrepancy is Si-carbonate replacement in shell, a suggested explanation for the Si contained in bivalve shell from nearby Long Island Sound (Messeck et al. 2018). It is also possible that as suspended particulates pass through the oyster digestive system, some of the Si held in these particles dissolves and is assimilated by the oyster. We can make no conclusive assertions here.

At an ecosystem level, the ratio of nutrient regeneration in oyster habitats can play an important role in regulating phytoplankton community composition; diatoms should dominate when Si:N availability is ≥ 1 . We can estimate how the oyster farm might alter water column Si:N ratios using previously published values from this farm. Previously, we reported that sediments beneath aquaculture at this farm recycle dissolved ammonium ($192 \mu mol NH_4^+ m^{-2} h^{-1}$) at a higher rate than bare sediments ($-42 \mu mol NH_4^+ m^{-2} h^{-1}$) with no change in NO_3^- or NO_2^- flux (Ray et al. 2020). We also determined that oysters recycle N at a rate of $1.47 \mu mol N ind.^{-2} h^{-1}$

(as NH_4^+ and NO_2^- ; Ray et al. 2019). Assuming a stocking density of 500 oysters m^{-2} , total N recycling in the aquaculture facility on a spatial basis is approximately $927 \mu\text{mol N m}^{-2} \text{h}^{-1}$ —much less than the sum of DSi recycling beneath aquaculture and oyster uptake ($2446 \mu\text{mol DSi m}^{-2} \text{h}^{-1}$). It appears that oyster aquaculture recycles Si:N at 2.6, creating conditions favorable for a phytoplankton community dominated by diatoms.

An ecosystem-scale demonstration of the importance of suspension-feeder-driven Si regeneration can be found in the Bay of Brest, France. Observations of persistent diatom populations throughout the summer in the bay despite low Si loading were determined to be driven by enhanced sediment DSi regeneration driven by benthic OM loading by invasive *Crepidula fornicata*—in effect creating a ‘silicic acid pump’ that could maintain Si availability for diatoms in the water column (Chauvaud et al. 2000, Ragueneau et al. 2002). It is likely that large oyster populations have a similar effect.

4.2. Oyster aquaculture is a relatively small Si sink

When oysters are harvested for human consumption the ASi they contain is removed from the system. We can estimate the relative importance of ASi removal via oyster harvest in Ninigret Pond by comparing the values we measured in this study with estimates of Si loading to the system. Assuming groundwater Si loading to Ninigret Pond proceeds at approximately $0.6 \text{ DSi mmol m}^{-2} \text{h}^{-1}$ (Grace & Kelley 1981, Bintz et al. 2003) and the lagoon has an area of approximately 6.4 km^2 , the total annual Si input is approximately $33638.4 \text{ kmol Si yr}^{-1}$. Unfortunately, we cannot locate data on oyster harvest from Ninigret Pond alone, but can use the 2015 harvest data for the entire state of Rhode Island (8.3×10^6 oysters from culture harvested; Beutel 2017), which encompasses Ninigret Pond, Narragansett Bay, and several other small coastal lagoons. If we assume all oysters were the same size, all came from Ninigret Pond, and all contained the same amount of ASi ($0.25 \text{ g ASi ind.}^{-1}$), then total ASi removed through oyster harvest would equal 350 kg, or 5.83 kmol Si —even if all of the oysters raised in Rhode Island were raised and harvested in Ninigret Pond, this harvest would only remove 0.02% of total Si loading to the system, and even less if there are other sources with large Si quantities besides groundwater. Thus, we can conclude that removal of Si in oyster biomass does not

have a large impact on estuarine Si cycling or export of Si to the ocean.

Si burial in sediments beneath oyster aquaculture also appears negligible, as there are only very slight differences in ASi concentrations at 3–4 cm depth beneath oyster aquaculture and bare sediment (Fig. 4). Despite greater ASi loading to surface sediments beneath aquaculture, the majority of this ASi is dissolved as it is buried, demonstrated by higher sediment porewater DSi concentrations as aquaculture age increases. The DSi in this porewater is moved to the water column through diffusive processes, driving the enhanced DSi fluxes from sediments beneath oyster aquaculture gear (Fig. 3).

4.3. Comparing aquaculture with oyster reefs

In this study, we investigated the influence of oyster aquaculture on estuarine Si cycling. Oyster reefs likely have a similar impact as aquaculture in regards to oyster and sediment DSi fluxes, though ASi removal and burial likely differs between reefs and aquaculture. Specifically, we predict that oysters on reefs will contain more ASi than those raised in aquaculture, and burial of ASi will be greater in oyster reef habitats relative to aquaculture. Oysters growing on reefs tend to have a greater shell mass relative to tissue mass compared to oysters raised in culture, which often have relatively thinner shells due either to protection from predation in cages, selection of oysters that provision more energy to tissue than shell growth by farmers, or directly by alteration of shell shape and mass during farm management (e.g. tumbling oysters to chip shells; Higgins et al. 2011). If reef oysters are harvested, more Si may be removed from the system relative to a similarly sized harvest of oysters raised in culture, but the magnitude of this removal is still likely insignificant at the ecosystem scale. Burial of ASi in oyster reefs may be much higher than aquaculture, driven not through greater burial of ASi-containing biodeposits, but directly through shell burial. Mature oyster reefs bury and store large quantities of inorganic carbon (C) in shell ($0.5\text{--}2.5 \text{ Mg C ha}^{-1} \text{ yr}^{-1}$; Fodrie et al. 2017), and using this burial rate, the inorganic-C content of oyster shell (11% shell mass; Galtsoff 1964), and the average ASi content of oyster shell (0.55%) we can estimate that shell burial in oyster reefs could sequester between 0.03 and $0.13 \text{ Mg Si ha}^{-1} \text{ yr}^{-1}$, or $5.7\text{--}24.7 \mu\text{mol ASi m}^{-2} \text{h}^{-1}$. This burial is fairly small, at approximately 1–4% of the groundwater loading rate to Ninigret Pond on an aerial basis.

5. CONCLUSIONS

Results of our study demonstrate that the expansion of oyster aquaculture will lead to more rapid recycling of Si in coastal ecosystems, with little Si loss. In systems with substantial oyster aquaculture activity, larger diatom populations might be favored due to greater Si availability, with ecosystem-scale consequences. In this study, we measured Si cycling at an oyster farm due to convenience, as well as the challenge of locating oyster reefs in the Northeastern USA. However, we suspect that much like N and P, oyster-mediated Si cycling will be similar in aquaculture and reef habitats and that other filter-feeding bivalves may have similar effects. These questions are certainly worthy of further investigation and may shed light on how coastal ecosystems functioned prior to over-exploitation of oyster populations.

Data availability. The data sets used in this study can be accessed and downloaded via the Figshare repository (<https://doi.org/10.6084/m9.figshare.14497566>).

Acknowledgements. This study was funded by a Rhode Island Sea Grant award to R.W.F., a Boston University Undergraduate Research Opportunity award and funding from the Boston University Marine Program to M.C.H., and Boston University Graduate Fellowship funding through the Department of Biology for N.E.R. and T.J.M. We are grateful for field and laboratory assistance from Sarabeth Buckley, Emily Chua, Boze Hancock, Gabby Hillyer, Sarah Donovan, Suzy Ayvazian, Donn Cobb, Charley Strobel, Maya Babu, Gretchen McCarthy, Siobahn Sheehan, and Lucy Zipf. We thank the US EPA Atlantic Ecology Division for providing boat transport to the site and are especially grateful to Dave Beutel from the RI Coastal Resources Management Council for assisting in site selection and introducing us to Jim Arnoux, who let us sample at his oyster farm.

LITERATURE CITED

- Asmus H, Asmus R, Reise K (1990) Exchange processes in an intertidal mussel bed: a Sylt-flume study in the Wadden Sea. *Ber Biol Anst Helgol* 6:1–79
- ▶ Bartoli M, Nizzoli D, Viaroli P, Turolla E, Castaldelli G, Fano EA, Rossi R (2001) Impact of *Tapes philippinarum* farming on nutrient dynamics and benthic respiration in the Sacca di Goro. *Hydrobiologia* 455:203–212
- ▶ Bates D, Maechler M, Bolker B, Walker S (2015) Fitting linear mixed-effects models using lme4. *J Stat Softw* 67:1–48
- ▶ Beck MW, Brumbaugh RD, Airoidi L, Carranza A and others (2011) Oyster reefs at risk and recommendations for conservation, restoration, and management. *BioScience* 61:107–116
- ▶ Berg P, McGlathery KJ (2001) A high-resolution pore water sampler for sandy sediments. *Limnol Oceanogr* 46:203–210
- Beutel D (2017) Aquaculture in Rhode Island 2017. Rhode Island Coastal Resources Management Council, Wakefield, RI
- ▶ Bintz JC, Nixon SW, Buckley BA, Granger SL (2003) Impacts of temperature and nutrients on coastal lagoon plant communities. *Estuaries* 26:765–776
- ▶ Bolker BM, Brooks ME, Clark CJ, Geange SW, Poulsen JR, Stevens MHH, White JSS (2009) Generalized linear mixed models: a practical guide for ecology and evolution. *Trends Ecol Evol* 24:127–135
- ▶ Boothroyd JC, Friedrich NE, McGinn SR (1985) Geology of microtidal coastal lagoons: Rhode Island. *Mar Geol* 63:35–76
- Brown LP, Koener JS (1889) Analysis of oyster shells and oyster shell lime. *J Am Chem Soc* 11:36–37
- ▶ Carey JC, Fulweiler RW (2014) Silica uptake by *Spartina*—evidence of multiple modes of accumulation from salt marshes around the world. *Front Plant Sci* 5:186
- ▶ Chauvaud L, Jean F, Ragueneau O, Thouzeau G (2000) Long-term variation of the Bay of Brest ecosystem: benthic–pelagic coupling revisited. *Mar Ecol Prog Ser* 200:35–48
- ▶ Conley DJ (1998) An interlaboratory comparison for the measurement of biogenic silica in sediments. *Mar Chem* 63:39–48
- Conley DJ, Schelske CL (2001) Biogenic silica. In: Smol JP, Birks HJ, Last WM (eds) Tracking environmental change using lake sediments: biological methods and indicators, Vol 3. Kluwer Academic Press, Dordrecht, p 281–293
- Dalsgaard T, Nielsen LP, Brotas V, Viaroli P and others (2000) Protocol handbook for NICE-nitrogen cycling in estuaries: a project under the EU research programme: Marine Science and Technology (MAST III). National Environmental Research Institute, Silkeborg
- Dame RF (2012) Ecosystem metabolism and nutrient cycling. In: Ecology of marine bivalves: an ecosystem approach, 2nd edn. Taylor & Francis, Boca Raton, FL, p 197–206
- ▶ Dame RF, Zingmark RG, Haskin E (1984) Oyster reefs as processors of estuarine materials. *J Exp Mar Biol Ecol* 83:239–247
- ▶ Dame RF, Dankers N, Prins T, Jongmsma H, Smaal A (1991) The influence of mussel beds on nutrients in the western Wadden Sea and Eastern Scheldt estuaries. *Estuaries* 14:130–138
- ▶ Dame RF, Spurrier JD, Zingmark RG (1992) *In situ* metabolism of an oyster reef. *J Exp Mar Biol Ecol* 164:147–159
- ▶ Delignette-Muller LM, Dutang C, Denis J (2015) ftdistribplus: an R package for fitting distributions. *J Stat Softw* 64:1–34
- ▶ DeMaster DJ (1981) The supply and accumulation of silica in the marine environment. *Geochim Cosmochim Acta* 45:1715–1732
- ▶ Doering PH, Kelly JR, Oviatt CA, Sowers T (1987) Effect of the hard clam *Mercenaria mercenaria* on benthic fluxes of inorganic nutrients and gases. *Mar Biol* 94:377–383
- ▶ Doering PH, Oviatt CA, Beatty LL, Banzon VF and others (1989) Structure and function in a model coastal ecosystem: silicon, the benthos and eutrophication. *Mar Ecol Prog Ser* 52:287–299
- ▶ Duarte CM, Agusti S, Barbier E, Britten GL and others (2020) Rebuilding marine life. *Nature* 580:39–51
- ▶ Dugdale RC, Wilkerson FP (1998) Silicate regulation of new production in the equatorial Pacific upwelling. *Nature* 391:270–273
- ▶ Dugdale RC, Wilkerson FP, Minas HJ (1995) The role of a silicate pump in driving new production. *Deep Sea Res* 42:697–719
- ▶ Egge JK, Aksnes DL (1992) Silicate as a regulating nutrient

- in phytoplankton competition. *Mar Ecol Prog Ser* 83: 281–289
- FAO (2020) The state of world fisheries and aquaculture 2020. Sustainability in action. FAO, Rome
- ✦ Fodrie FJ, Rodriguez AB, Gittman RK, Grabowski JH and others (2017) Oyster reefs as carbon sources and sinks. *Proc R Soc B* 284:20170891
- Gaertner-Mazouni N, Lacoste E, Bodoy A, Peacock L and others (2012) Nutrient fluxes between water column and sediments: potential influence of the pearl oyster culture. *Mar Pollut Bull* 65:500–505
- Galtsoff P (1964) The American oyster *Crassostrea virginica* Gmelin. *Fish Bull Fish Wildl Serv* 64:1–456
- Galtsoff E, Hole W, Costello DP, Edwards RL and others (1964) The American oyster, 1964. *Fish Bull* 64:1–458
- Grace J, Kelley W (1981) Fresh water input to Rhode Island coastal ponds. Report to Coastal Resource Center, University of Rhode Island, Narragansett, RI
- ✦ Green DS, Rocha C, Crowe TP (2013) Effects of non-indigenous oysters on ecosystem processes vary with abundance and context. *Ecosystems* 16:881–893
- ✦ Higgins CB, Stephenson K, Brown BL (2011) Nutrient bioassimilation capacity of aquacultured oysters: quantification of an ecosystem service. *J Environ Qual* 40:271–277
- ✦ Hougham AL, Moran SB (2007) Water mass ages of coastal ponds estimated using ^{223}Ra and ^{224}Ra as tracers. *Mar Chem* 105:194–207
- ✦ Humphries AT, Ayvazian SG, Carey JC, Hancock BT and others (2016) Directly measured denitrification reveals oyster aquaculture and restored oyster reefs remove nitrogen at comparable high rates. *Front Mar Sci* 3:74
- Hunter AC, Harrison CW (1928) Bacteriology and chemistry of oysters, with special reference to regulatory control of production, handling, and shipment. Technical Bulletin No. 64. US Department of Agriculture, Washington, DC
- ✦ Kellogg ML, Cornwell JC, Owens MS, Paynter KT (2013) Denitrification and nutrient assimilation on a restored oyster reef. *Mar Ecol Prog Ser* 480:1–19
- ✦ Lee V, Olsen S (1985) Eutrophication and management initiatives for the control of nutrient inputs to Rhode Island coastal lagoons. *Estuaries* 8:191–202
- Lenth R (2018) emmeans: estimated marginal means, aka least-squares means. R package version 1.2.3. <https://github.com/rvnlenth/emmeans>
- ✦ Li J, Ianaiev V, Huff A, Zalusky J, Ozersky T, Katsev S (2021) Benthic invaders control the phosphorus cycle in the world's largest freshwater ecosystem. *Proc Natl Acad Sci USA* 118:e2008223118
- ✦ Mackenzie CL (2007) Causes underlying the historical decline in Eastern oyster (*Crassostrea virginica* Gmelin, 1791) landings. *J Shellfish Res* 26:927–938
- Masterson JP, Sorenson JR, Stone JR, Moran SB, Hougham AL (2007) Hydrogeology and simulated ground-water flow in the Salt Pond region of southern Rhode Island. Scientific Investigations Report No. 2006–5271. US Geological Survey, Reston, VA
- ✦ Meseck SL, Mercaldo-Allen R, Kuropat C, Clark P, Goldberg R (2018) Variability in sediment-water carbonate chemistry and bivalve abundance after bivalve settlement in Long Island Sound, Milford, Connecticut. *Mar Pollut Bull* 135:165–175
- Newell RIE (1988) Ecological changes in Chesapeake Bay: Are they the result of overharvesting the American oyster, *Crassostrea virginica*? In: Lynch MP, Krome EC (eds) Understanding the estuary: advances in Chesapeake Bay research. Proceedings of a conference, 29–31 March 1988, Baltimore, MD. Chesapeake Research Consortium, Baltimore, MD, p 536–546
- Newell R, Fisher T, Holyoke R, Cornwell J (2005) Influence of eastern oysters on nitrogen and phosphorus regeneration in Chesapeake Bay, USA. In: Dame RF, Olenin S (eds) The comparative roles of suspension-feeders in ecosystems. Springer, Dordrecht, p 93–120
- ✦ Peterson BJ, Heck KL (1999) The potential for suspension feeding bivalves to increase seagrass productivity. *J Exp Mar Biol Ecol* 240:37–52
- ✦ Porter ET, Franz H, Lacouture R (2018) Impact of eastern oyster *Crassostrea virginica* biodeposit resuspension on the seston, nutrient, phytoplankton, and zooplankton dynamics: a mesocosm experiment. *Mar Ecol Prog Ser* 586:21–40
- ✦ Porter ET, Robins E, Davis S, Lacouture R, Cornwell JC (2020) Effects of resuspension of eastern oyster *Crassostrea virginica* biodeposits on phytoplankton community structure. *Mar Ecol Prog Ser* 640:79–105
- ✦ Prairie YT (1996) Evaluating the predictive power of regression models. *Can J Fish Aquat Sci* 53:490–492
- ✦ Prins TC, Smaal AC, Dame RF (1997) A review of the feedbacks between bivalve grazing and ecosystem processes. *Aquat Ecol* 31:349–359
- ✦ Ragueneau O, Chauvaud L, Leynaert A, Thouzeau G and others (2002) Direct evidence of a biologically active coastal silicate pump: ecological implications. *Limnol Oceanogr* 47:1849–1854
- ✦ Ragueneau O, Schultes S, Bidle K, Claquin P, Moriceau B (2006) Si and C interactions in the world ocean: importance of ecological processes and implications for the role of diatoms in the biological pump. *Global Biogeochem Cycles* 20:GB4S02
- ✦ Ray NE, Fulweiler RW (2021) Meta-analysis of oyster impacts on coastal biogeochemistry. *Nat Sustain* 4:261–269
- ✦ Ray NE, Henning MC, Fulweiler RW (2019) Nitrogen and phosphorus cycling in the digestive system and shell biofilm of the eastern oyster (*Crassostrea virginica*). *Mar Ecol Prog Ser* 621:95–105
- ✦ Ray NE, Al-Haj AN, Fulweiler RW (2020) Sediment biogeochemistry along an oyster aquaculture chronosequence. *Mar Ecol Prog Ser* 646:13–27
- ✦ Sauer D, Saccone L, Conley DJ, Herrmann L, Sommer M (2006) Review of methodologies for extracting plant-available and amorphous Si from soils and aquatic sediments. *Biogeochemistry* 80:89–108
- ✦ Sma RF, Baggaley A (1976) Rate of excretion of ammonia by the hard clam *Mercenaria mercenaria* and the American oyster *Crassostrea virginica*. *Mar Biol* 36:251–258
- Smaal AC, Prins TC (1993) The uptake of organic matter and the release of inorganic nutrients by bivalve suspension feeder beds. In: Dame RF (ed) Bivalve filter feeders in estuarine and coastal ecosystem processes, 1st edn. Springer-Verlag, Berlin Heidelberg, p 271–298
- Smith RA, Wright ER (1962) Elemental composition of oyster shell. *Tex J Sci* 14:222–224
- Strickland J, Parsons T (eds) (1968) A practical handbook of seawater analysis. Queen's Printer, Ottawa
- ✦ Svenningsen NB, Heisterkamp IM, Sigby-Clausen M, Larsen LH, Nielsen LP, Stief P, Schramm A (2012) Shell biofilm nitrification and gut denitrification contribute to emission of nitrous oxide by the invasive freshwater mussel *Dreissena polymorpha* (Zebra mussel). *Appl Environ Microbiol* 78:4505–4509

-
- ✦ Tamburri MN, Zimmer-Faust RK, Tamplin ML (1992) Natural sources and properties of chemical inducers mediating settlement of oyster larvae: a re-examination. *Biol Bull (Woods Hole)* 183:327–338
 - ✦ Tréguer P, Pondaven P (2000) Silica control of carbon dioxide. *Nature* 406:358–359
 - ✦ Turner RE, Qureshi N, Rabalais NN, Dortch Q, Justic D, Shaw RF, Cope J (1998) Fluctuating silicate:nitrate ratios and coastal plankton food webs. *Proc Natl Acad Sci USA* 95:13048–13051
 - ✦ Wall CC, Peterson BJ, Gobler CJ (2008) Facilitation of sea-grass *Zostera marina* productivity by suspension-feeding bivalves. *Mar Ecol Prog Ser* 357:165–174
 - ✦ Welsh DT, Castadelli G (2004) Bacterial nitrification activity directly associated with isolated benthic marine animals. *Mar Biol* 144:1029–1037
 - ✦ Zu Ermgassen PSE, Spalding MD, Blake B, Coen LD and others (2012) Historical ecology with real numbers: past and present extent and biomass of an imperilled estuarine habitat. *Proc R Soc B* 279:3393–3400

*Editorial responsibility: Erik Kristensen,
Odense, Denmark
Reviewed by: 2 anonymous referees*

*Submitted: April 27, 2021
Accepted: June 21, 2021
Proofs received from author(s): August 27, 2021*